

MultiX DT-8000

Portable Integrated TSCM Equipment



Contents

Introduction	1
Overview	1
Function Highlights	1
Safety Instructions	2
Technical Principles	3
Technical Parameters	4
Name of Main Unit Parts	6
System Components	7
Carrying Case	7
System Interface	8
Login Interface	8
Quick Detection Interface (Home Page)	9
Wireless Signal Detection Interface	9
WiFi Detection Interface	10
WiFi Tracking Interface	14
Bluetooth Detection Interface	17
Bluetooth Tracking Interface	20
Mobile Signal Detection Interface	22
Mobile Signal Tracking Interface	25
Audio and Video Signal Detection Interface	27
Camera Detection Interface	30
Endoscope Detection Interface	33
Nonlinear Junction Linkage Detection Interface	34
Process Detection Interface	35

System Settings Interface 37

Security Audit Interface 38

Data Management Interface 39

How to Use 40

 Power On 40

 Tracking Compass Geomagnetic Calibration 41

 WiFi Detection 42

 Bluetooth Detection 43

 Mobile Communication Signal Detection 44

 Audio and Video Signal Detection 45

 Hidden Camera Detection 46

 Infrared Thermal Imaging Detection 47

 Endoscope Detection 48

 Nonlinear Junction Linkage Detection 49

 Export Detection Report 50

 Screen Switch 50

 Equipment Charging 50

 Power Off 50

Troubleshooting 51

Maintenance 53

Introduction

Overview

Portable Integrated TSCM Equipment, which can provide one-stop WiFi, Bluetooth, mobile signal, infrared thermal imaging, hidden camera, endoscope, audio and video restoration, and nonlinear junction function linkage detection. The product adopts integrated antenna design and skinning process, portable and easy to use.

Function Highlights

1. Excellent performance: The equipment has passed rigorous tests and has been certified by professional evaluation, with advanced technology and superior performance.
2. Integrated design: new integrated design, integration of multi-functional modules and antenna built-in, easy to operate, ready to use.
3. Eight-in-one function integration: Innovative integration of eight detectioncore technologies, without switching products, to meet the diverse needs of environmental safety detection.
4. High-end technology: Adopt unique skinning technology to enhance product durability, while the appearance is more beautiful and atmospheric.
5. Innovative linkage: Support linkage with nonlinear junction detector to effectively record detection data and enhance the accuracy of detection and analysis.
6. Intelligent Traceability: Intelligent, process-oriented and standardized detection process, which can automatically generate and compare the detection report to facilitate the traceability and analysis of the results.

Safety Instructions

1. Before using the product, please read the user manual carefully, operate correctly according to the instructions in the manual, and keep the user manual properly.
2. This product is used in indoor environment, please do not use it in high temperature, high humidity, strong magnetic field or strong static electricity environment.
3. Avoid dropping, rain, long time exposure to the sun, etc. when using this product, and disassembling the product is prohibited.
4. Please use the original charger, charging cable for equipment charging, long-term non-use, need to ensure that at least every 3 months to carry out a charging and discharging cycle.
5. When the equipment and accessories are not in use, they should be properly stored in a cool place to avoid dust, water vapor, direct sunlight and other damage to the equipment and accessories.

The illustrations of products, accessories, user interface, etc. in this manual are schematic diagrams for reference only. Due to product updates and upgrades, there may be slight differences between the actual product and the illustrations, please refer to the actual product.

Technical Principles

In order to effectively identify and prevent potential eavesdropping and bugging threats, the transmission mechanism and hardware composition of eavesdropping and bugging devices are comprehensively analyzed to accurately identify their technical characteristics. The equipment integrates eight functional modules, including infrared thermal imaging, camera detection, WiFi detection, Bluetooth signal detection, mobile communication signal detection, 5.8G camera video detection, FM audio detection, and endoscope detection, forming an all-around detection platform. These functional modules can not only operate independently, but also collaborate with each other to provide a comprehensive anti-eavesdropping and eavesdropping solution. Infrared thermal imaging reveals hidden heat sources, camera detection locates hidden camera devices, and WiFi, Bluetooth and cellular signal detection identifies anomalous wireless transmission activity. 5.8G camera video detection and FM audio detection further enhance the system's surveillance capabilities, and endoscope detection is suitable for small or enclosed spaces that are difficult to observe directly.

In addition, the system supports linkage with nonlinear junction technology, which utilizes nonlinear junction detection to identify and locate hidden electronic devices. The core of this technology lies in detecting the nonlinear response of semiconductor components under specific excitations, thus revealing hidden eavesdropping and bugging devices. It can be customized to meet the security detection needs of different scenarios, be it government agencies, corporate office environments or private residences.

Technical Parameters

Weight	<1.75kg
Display terminal screen size	10.1 inch
Screen resolution	1920*1200
Storage capacity	256GB
Storage video pixel	Infrared thermal imaging 384*288, endoscope detection 1920*1080
USB data interface	USB-A*1, USB-C* 1
Charging time	Approx. 2h
Operating time	>2.5h
WIFI detection	supports detection of WIFI frequency band supports detecting WIFI signals analyzing 802.11 a/b/g/n/ac/ax protocols.
Bluetooth signal detection	Detect and analyze Bluetooth signals of Bluetooth protocol 1.0, 2.0, 3.0, 4.0, 5.2.
Mobile Communication Detection Frequency Bands ^[1]	B3 1710-1785MHz B8 880-915MHz B5 824-849MHz n28 703-748MHz B40 2300-2400MHz B34 2010-2025MHz B1 1920-1980MHz B39 1880-1920MHz n79 4800-5000MHz n78 3300-3800MHz n41 2496-2690MHz

Infrared thermal imaging detection	Temperature measurement range: -20°C ~ +150°C Supports setting alarm threshold temperature
Hidden camera detection	Detection distance: 0.1-5m
Endoscope detection	Physical pixels: ≥ 1 million Illumination mode: linearly adjustable light brightness
Audio/Video restore (Enhanced Version)	Supports detection of 5.8G video signals Supports detection of 76MHz~108MHz audio
Nonlinear linkage (Enhanced version)	Support linkage detection with nonlinear junction detector

[1] Please note that the above detection frequency bands follow international mobile communication standards; however, frequency allocation may vary across different countries and regions. If the local frequency bands do not match the supported frequency bands of the device, detection performance may degrade or fail. Before purchase and use, please ensure that the local frequency bands are compatible with the device to avoid affecting performance.

Name of Main Unit Parts

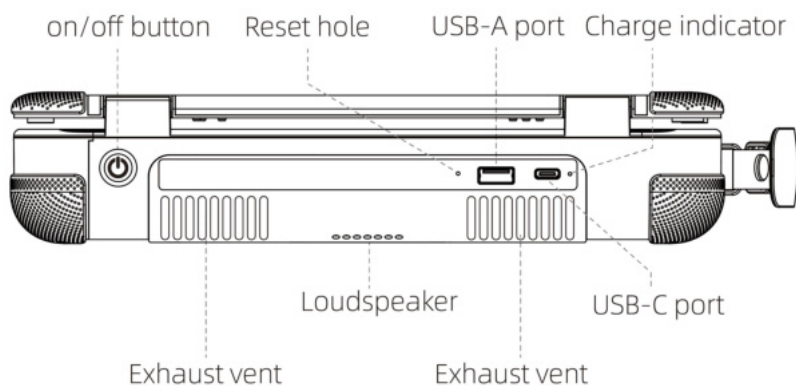
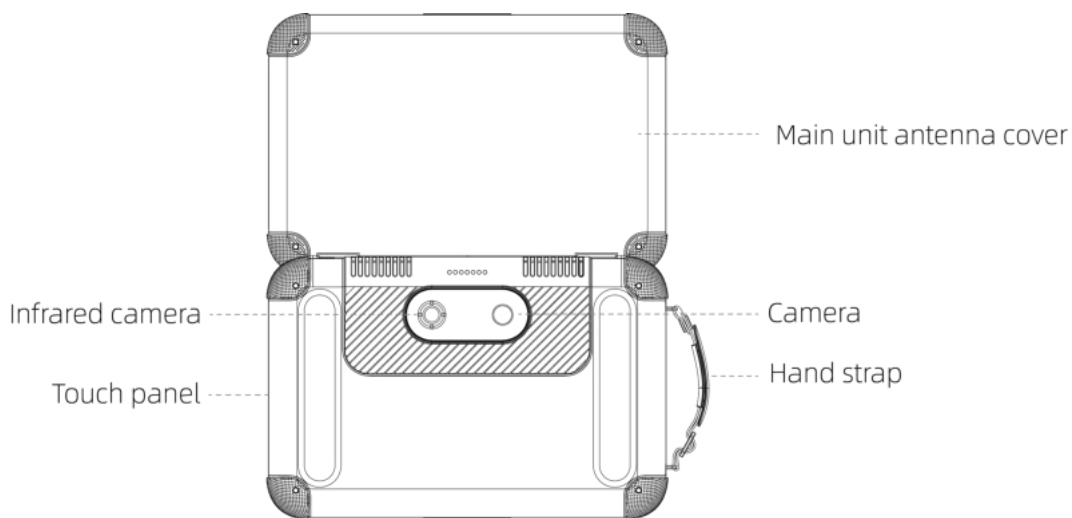

Do not disassemble factory-installed parts by yourself(except those permitted in the descriptions herein), or the product will not be warranted.

System Components

The following accessories are included with the Portable Integrated TSCM Equipment, if any damage or missing items are found, please contact the dealer who sold you this product.

- Main unit
- Endoscope
- User manual
- charger
- Carrying case

Carrying Case

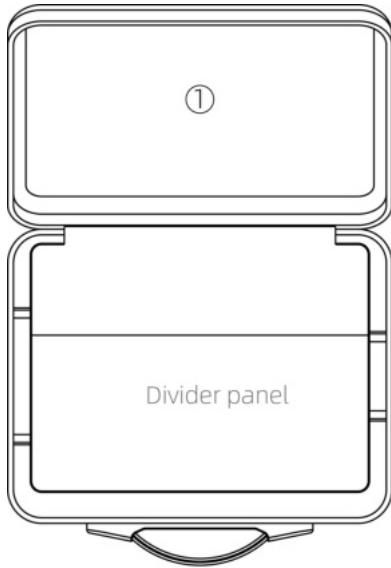

Carrying Case Upper

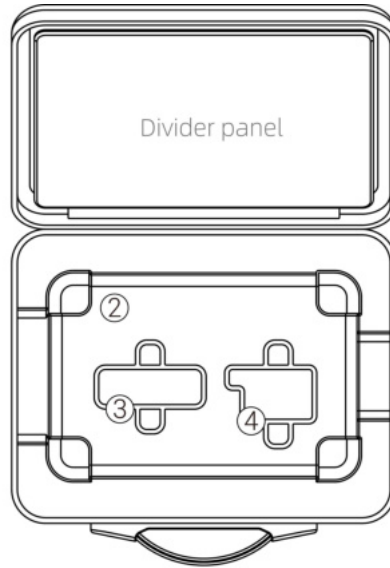

Carrying Case Lower

1. Endoscope

2. Main unit

3. Power Cord

4. Charger

System Interface

Login Interface

Long press the main unit on/off button  for 3 seconds to turn on the system, the power indicator will be on and the login interface will pop up. There are 4 groups of accounts in the system, you can select the account role to log in according to different situations. Logging in with any account will first enter the Quick Detection interface.

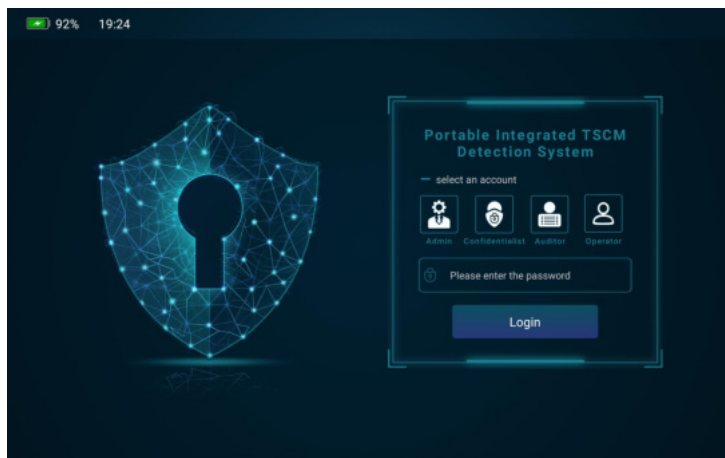

- Admin  (password: gly123):

Has full access.

- Confidentialist  (password: bmy123):

Audit function module is not open.

- Auditor  (password: sjy123):

Audit page to hide user data, can not view the system settings and process detection module.

- Operator  (password: czy123):

Can only operate quick detection, process detection.

Quick Detection Interface (Home Page)

There are 4 module buttons in the Quick Detection interface, Wireless Signal Detection module button, Camera Detection module button, Endoscope Detection module button, and Nonlinear Junction Linkage Detection module button, clicking on the buttons will lead you to the corresponding detection modules.



Wireless Signal Detection Interface

Tap the Wireless Signal Detection Module button in the Quick Detection Interface to enter the Wireless Detection Module. The Wireless Signal Detection Interface integrates four modules: WiFi Detection, Bluetooth Detection, Mobile Signal Detection and Audio/Video Detection, and you can enter the module by tapping the corresponding module button.

WiFi Detection Interface

This screen displays all the hotspots and terminals found at the user's location. Click the Track button to open the details of that hotspot or terminal.

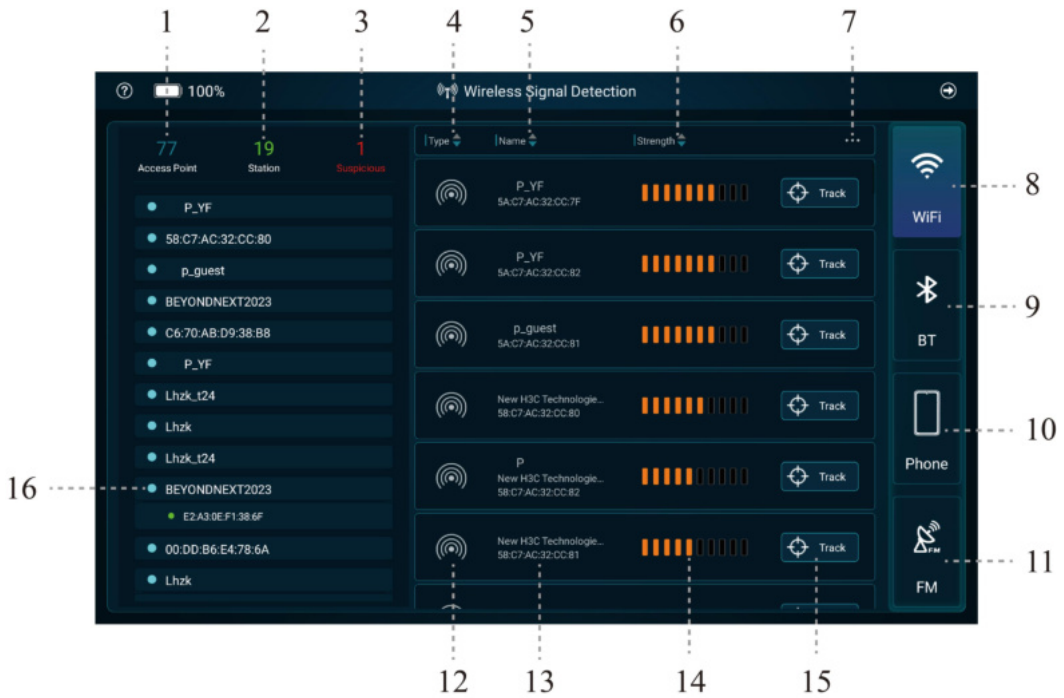

1. Number of hotspot devices

A hotspot device is a device that converts the GPRS, 3G or 4G signal it receives into a wifi signal and sends it out. The number of detected hotspot devices is 77.

2. Number of terminal devices

Terminal devices, i.e. computer display terminal devices. The number of terminal devices detected here is 19.

3. Number of suspicious devices

If the signal in the signal list is marked with red "suspicious", it indicates that the device is manually marked as a suspicious device or automatically identified by the system as a camera device, and has a high probability of being in the state of eavesdropping and eavesdropping. The current number of suspicious devices is 1.

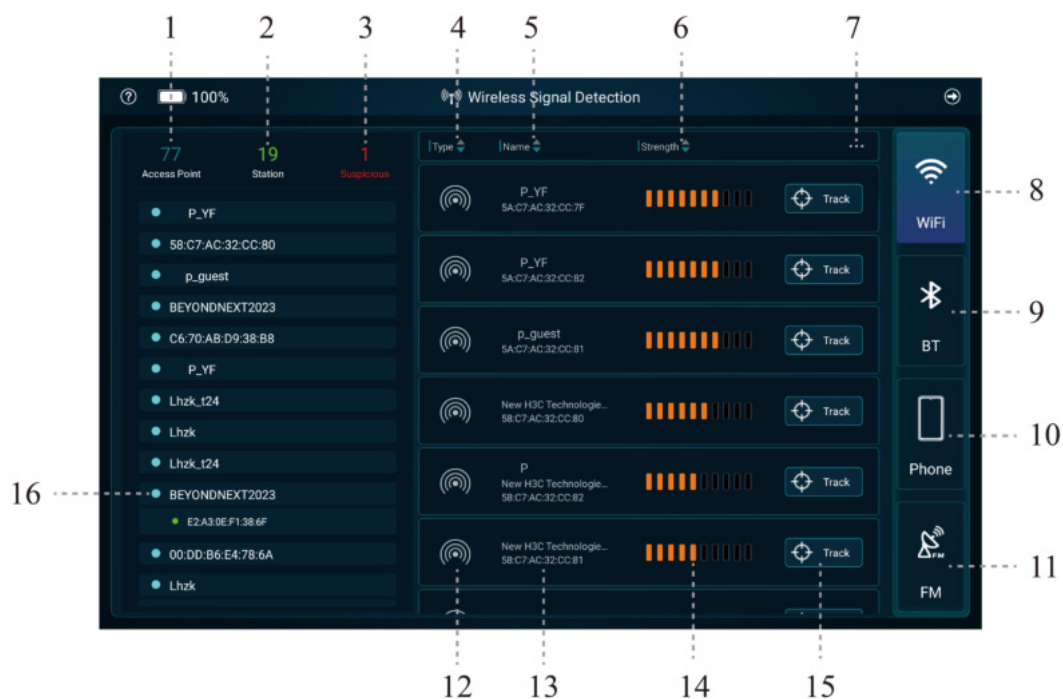

4. Signal type sorting button

Click the button to sort the signal list by signal type.

5. Signal MAC name sorting button

Click the button to sort the signals below by MAC name.

6. Signal strength sort button

Click on the button to sort the signal list below by signal strength from largest to smallest or smallest to largest.

7. Signal management button

Click to bring up black/white list management and data reset options.

8. WiFi Detection module button

The bottom color of this button shows that the WiFi detection module has been selected.

9. Bluetooth Detection module button

The bottom color of this button shows that the Bluetooth detection module has not been selected.

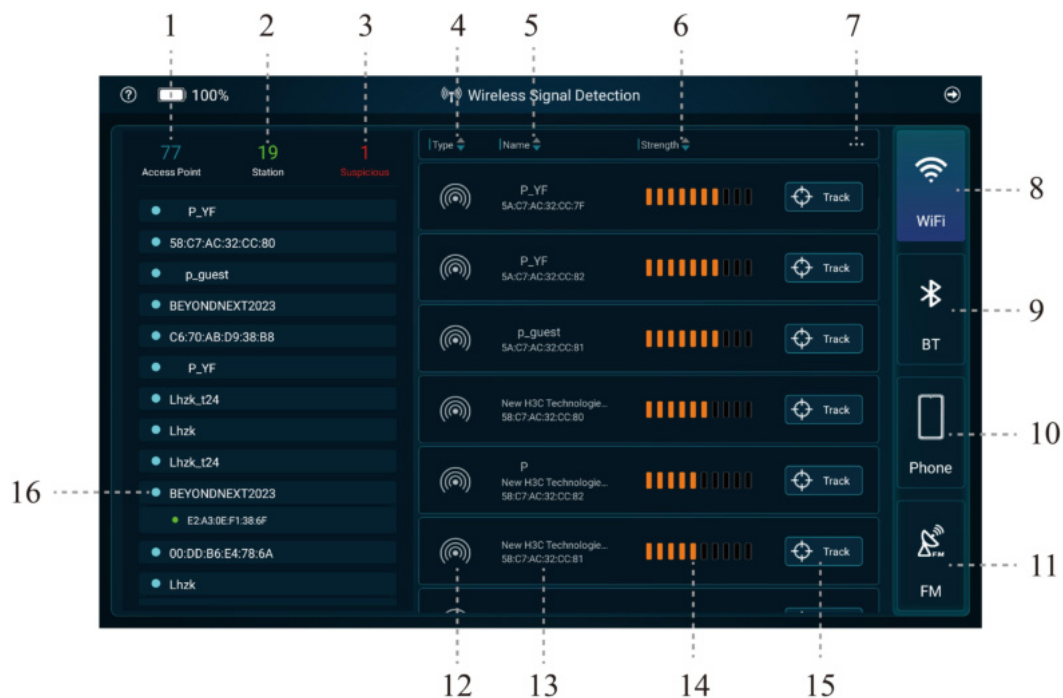

10. Mobile Signal Detection module button

The bottom color of this button shows that the mobile signal detection module has not been selected.

11. Audio/Video Detection module button

The bottom color of this button indicates that the audio/video detection module has not been selected.

12. Signal Type Icon

The following signal type icons may appear on the WiFi detection screen in this system:



13. MAC Name/Manufacturer Name and MAC Address

This displays the MAC name/manufacturer's name and MAC address of the corresponding signal.

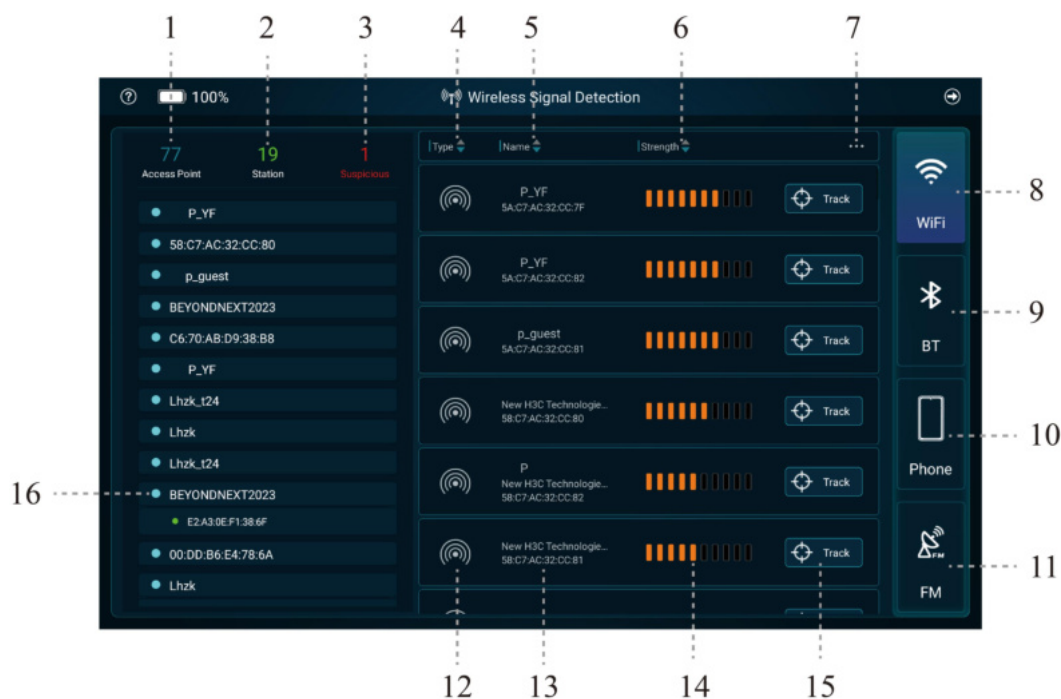

14. Signal Strength Icon

This displays the signal strength of the corresponding signal. More orange rectangles means stronger signal.

15. Signal Track Button

Click the Signal Track button to enter the corresponding signal tracking interface.

16. Signal Topology List

The topology shows the connection relationship between the hotspot and the terminal. Through this topology, you can know the information of connected terminals under the hotspot. The topology is linked with the signal list on the right side, click any network name/MAC address in the topology, the network/device will be displayed in the first line of the signal list on the right side, which is convenient to view further details.

WiFi Tracking Interface

Click the Track button  of a signal in the Signal Detection interface to enter the Signal Tracking screen.



1. Signal Strength of Tracked Signal

The signal strength of the tracked signal is -48db, the more orange rectangle bar means the stronger signal.

2. Detailed information of the tracked signal

This displays the name, MAC address, channel, service type, manufacturer, device type, encryption method, frequency and transmission rate of the traced signal.

3. Historical signal strength graph of the tracked signal

The horizontal axis represents the time point and the vertical axis represents the signal strength. Click on any vertex signal in the axis, the tracking compass will show the historical coordinate direction of the signal with gray dots.

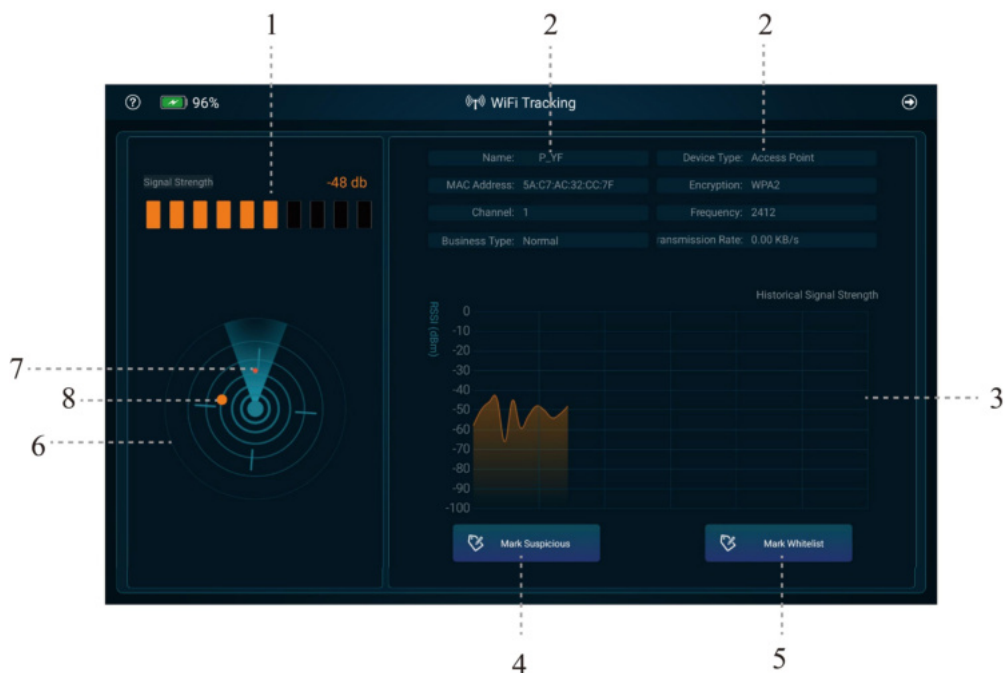

4. Mark Suspicious Device Button

Click the button to mark the current tracking signal as suspicious. After marking the signal as suspicious, the signal will be top in the signal list and the signal strength and related information will turn red.

5. Mark White List Device Button

Click the button to mark the current signal as white list.

6. Tracking Compass

The center of the circle on the compass indicates the current position of the equipment, and the fan-shaped area indicates the area where the equipment is pointed to.

7. Target Signal

The red dot indicates the current signal strength of the tracked target signal.

8. Target Signal Historical Signal Strength

The orange dot indicates the historical maximum signal strength direction of the tracked target signal.



Attention:

- WiFi detection supports detecting wireless signals in the 2.4GHz (b/g/n/ax) and 5GHz (a/n/ac/ax) bands.
- If the network name is not shown in the list, it means the network does not broadcast its SSID.
- If "Unknown Manufacturer" is shown in the list, it means the MAC address is private or unregistered.
- Once a network or device appears in the list, it remains in the list even if it is not subsequently detected or is out of current range. To exclude the device, click the Data Reset button to perform a new round of search.
- The topology map displays the network name if it can be resolved properly, otherwise the MAC address will be displayed.
- If you want to quickly view the terminal devices connected to a certain hotspot device, you can trace the hotspot device for 10~30 seconds and then return to the view list interface.

Bluetooth Detection Interface



1. Total number of Bluetooth devices

This displays the total number of currently detected Bluetooth devices, which is 49.

2. Number of Suspicious Devices

This shows the number of suspicious devices is 0.

3. Signal Type sorting button

Click this button to sort the signal list by signal type.

4. Signal Name Sort Button

Click this button to sort the signal list by signal name.

5. Signal Strength Sort Button

Click this button to sort the signal list below by signal strength from highest to lowest or lowest to highest.

6. Signal Management Button

Click to bring up black/white list management and data reset options.



7. WiFi Detection module button

The bottom color of this button shows that the WiFi detection module is not selected.

8. Bluetooth Detection module button

The bottom color of this button shows that the Bluetooth Detection module has been selected.

9. Mobile signal Detection module button

The bottom color of this button indicates that the mobile signal detection module is not selected.

10. Audio/Video Detection module button

The bottom color of this button indicates that the audio/video detection module is not selected.

11. Signal Type Icon

This displays the signal icon of the corresponding signal.

12. Signal Name and MAC Address

This displays the signal name and MAC address of the corresponding signal.



Signal name and MAC address of the corresponding signal are displayed here.

13. Signal Strength Icon

This displays the signal strength of the corresponding signal. More orange rectangles means stronger signal.

14. Signal Track Button

Click the Signal Track button to enter the corresponding signal tracking interface.

15. Number of Bluetooth by type

This displays a summary of the number of each Bluetooth type, including all Bluetooth, classic Bluetooth, low-power, Apple Bluetooth number.

Attention:

- Bluetooth detection supports detection of BR and LE Bluetooth.
- If the network name is not shown in the list, it means the network does not broadcast its SSID.
- If "Unknown Manufacturer" is shown in the list, it means the MAC address is private or unregistered.
- Once a network or device appears in the list, it remains in the list even if it is not subsequently detected or is out of current range. To exclude the device, click the Data Reset button to perform a new round of detect.

Bluetooth Tracking Interface

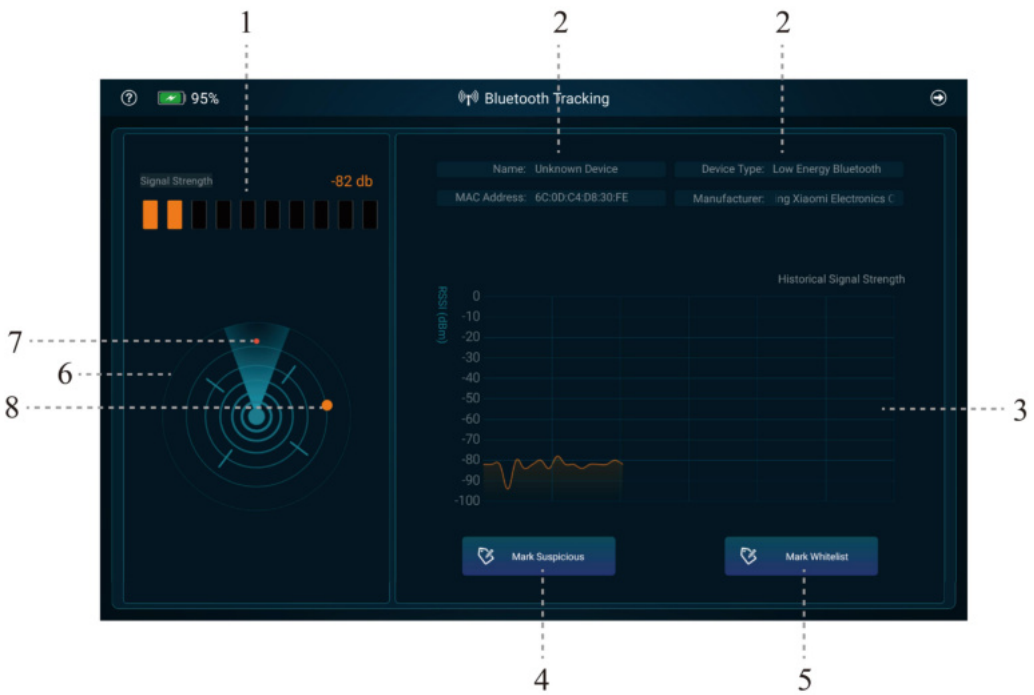

1. Signal Strength of Tracked Signal

The signal strength of the tracked signal is -82db, the more orange rectangle bar means the stronger signal.

2. Detailed information of the tracked signal

This displays the name, MAC address, device model, device type and manufacturer of the tracked signal.

3. Historical Signal Strength of Tracked Signal

The horizontal axis represents the time point and the vertical axis represents the signal strength. Click on any vertex signal in the axis, the tracking compass will show the historical coordinate direction of the signal with a gray dot.

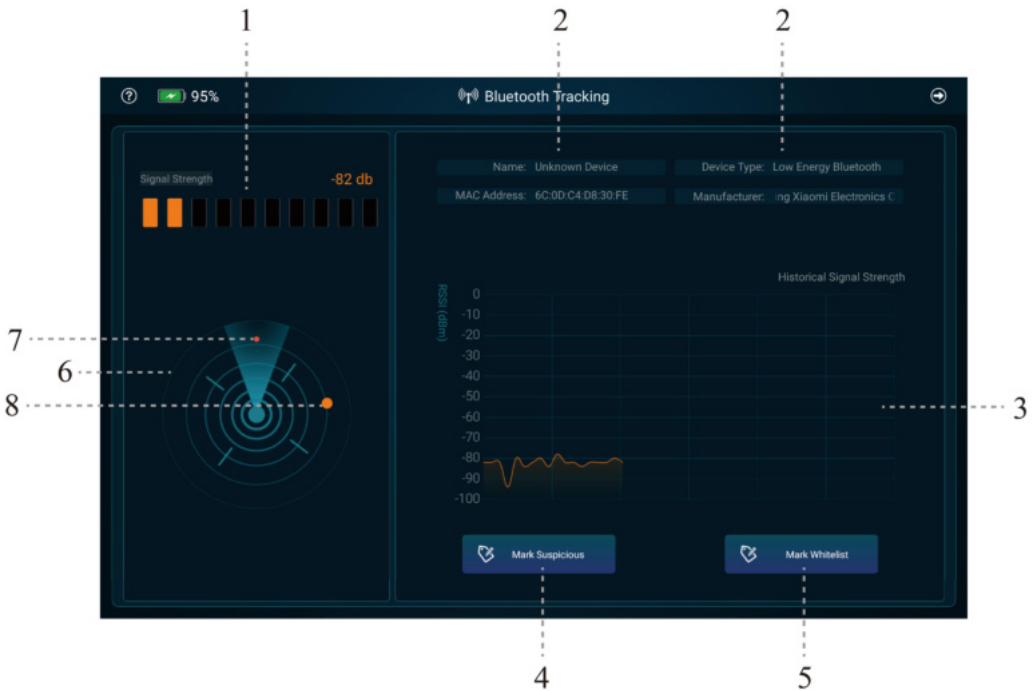

4. Mark Suspicious Device Button

Click the button to mark the current tracking signal as suspicious. After marking the signal as suspicious, the signal will be top in the signal list and the signal strength and related information will turn red.

5. Mark White List Device Button

Click the button to whitelist the current signal.

6. Tracking Compass

The center of the compass indicates the current position of the equipment, and the fan-shaped area indicates the area where the equipment is pointed to.

7. Target Signal

The red dot indicates the current signal strength of the tracked target signal.

8. Target Signal Historical Signal Strength

Orange dots indicate the historical maximum signal strength direction of the tracked target signal.

Mobile Signal Detection Interface



1. Signal Type sorting button

Click the button to sort the signal list below by signal type.

2. Signal Operator Sort Button

Click the button to sort the signal list by signal operator type.

3. Signal Strength Sort Button

Click this button to sort the list of signals by signal strength from highest to lowest or lowest to highest.

4. Frequency Management Button

Click this button to bring up the frequency setting options

5. Signal Management Button

Click the button to bring up the black/white list management and data reset options.

6. WiFi Detection Module Button

The bottom color of this button shows that the WiFi detection module has not been selected.



7. Bluetooth Detection module button

The bottom color of this button shows that the Bluetooth detection module has not been selected.

8. Mobile I Signal Detection module button

The bottom color of this button shows that the mobile signal detection module has been selected.

9. Audio/Video Detection module button

The bottom color of this button indicates that the audio/video detection module has not been selected.

10. Signal Type Icon

The following signal type icons may appear on the mobile signal detection screen in this system:

 Data is currently being consumed

 In calls



11. Signal Name and MAC Address

This displays the signal system, signal strength value, signal band and signal operator of the corresponding signal.

12. Signal Waveform Icon

This displays the signal waveform of the corresponding signal, and you can identify whether the signal exists by the waveform.

13. Signal Track Button

Click the signal tracking button to enter the corresponding signal tracking interface.

14. Signal Category List

Different types of detected signals are displayed here, click on the corresponding type, the signal list on the right side will be displayed synchronously.

Mobile Signal Tracking Interface



1. Signal Strength of Tracked Signal

The signal strength of the tracked signal is -34db, the more orange rectangle bar means the stronger signal.

2. Detailed information of the tracked signal

Here shows the carrier, standard, band and frequency of the tracked signal.

3. Tracked Signal Historical Signal Strength

The horizontal axis represents the time point, the vertical axis represents the signal strength.

4. Mark Suspicious Device Button

Click the button to mark the current tracked signal as suspicious. After marking the signal as suspicious, the signal will be top in the signal list and the signal strength and related information will turn red.

5. Mark White List Device Button

Click the button to whitelist the current signal.

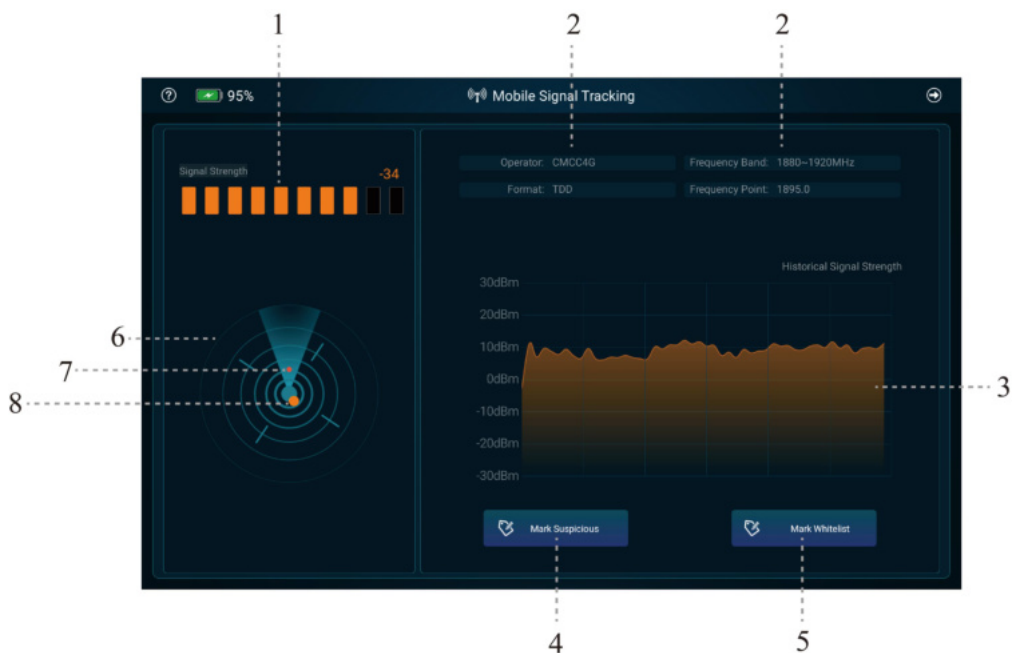

6. Tracking Compass

The center of the compass indicates the current position of the equipment, and the fan-shaped area indicates the area where the equipment is pointed to.

7. Target Signal

The red dot indicates the current signal strength of the tracked target signal.

8. Target Signal Historical Signal Strength

Orange dots indicate the historical maximum signal strength direction of the tracked target signal.

Audio and Video Signal Detection Interface

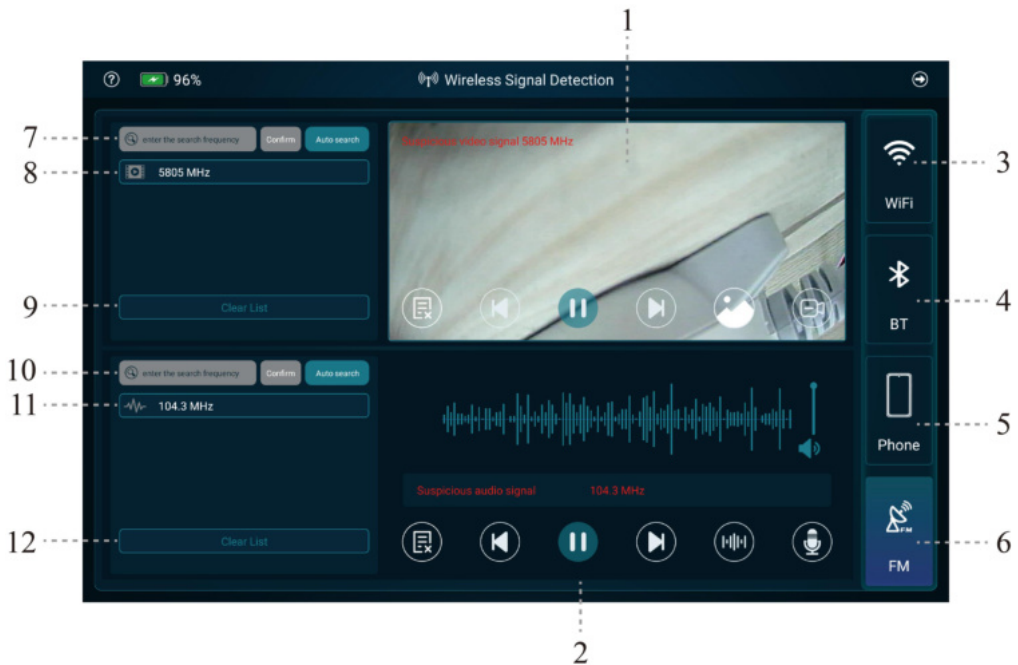

1. Video signal screen and operation area

You can mark, play/pause, previous/next frequency, record and other operations on the video signal.

2. Audio signal operation area

You can mark, play/pause, previous/next frequency, record, etc. for audio signal, and you can also adjust the volume.

3. WiFi Detection module button

The bottom color of this button shows that the WiFi detection module is not selected.

4. Bluetooth Detection module button

The bottom color of this button shows that the Bluetooth detection module has not been selected.

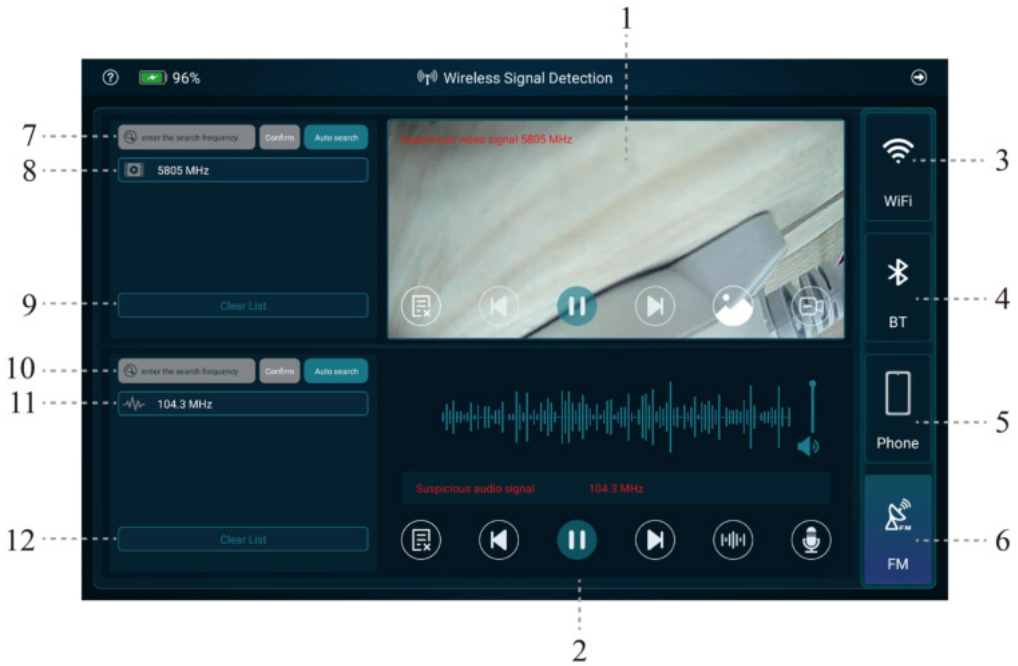

5. Mobile Signal Detection module button

The bottom color of this button shows that the mobile signal detection module has not been selected.

6. Audio and Video Signal Detection module button

Click the Audio and Video Signal Detection module button, the interface will display the Audio and Video signal detection interface, the bottom color of this button shows that the audio /video detection module has been selected.

7. Video Signal search box

Enter the search band in the search box and click the "Confirm" button on the right side to start searching, or click the "Auto search" button to search the video signal automatically.

8. Video Signal band list

This displays the detected video signal bands.

9. Clear button

Click this button to clear the detected video signal bands.

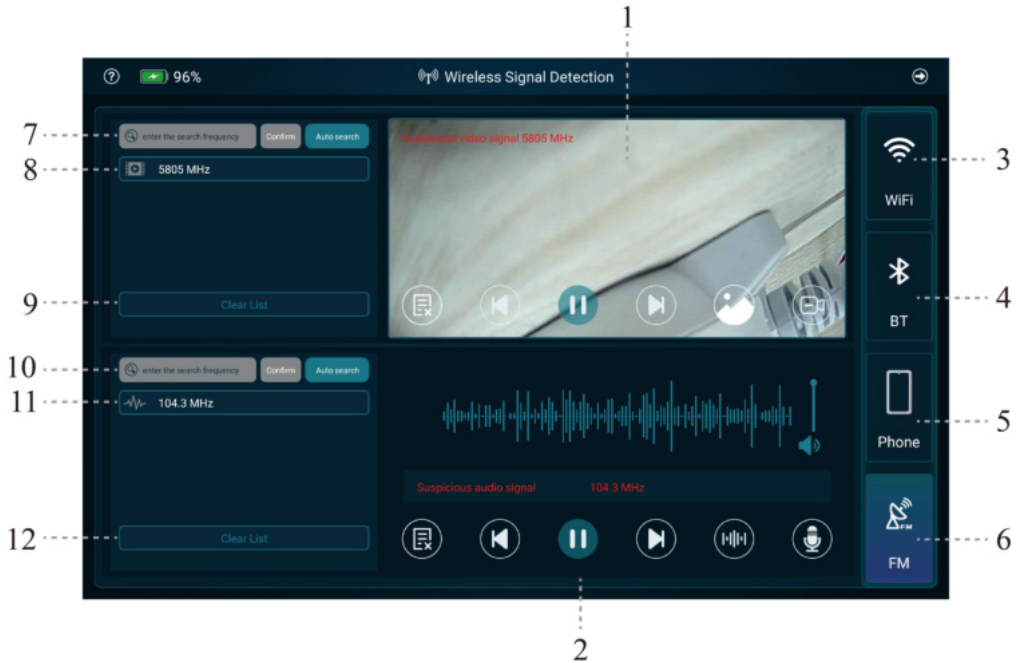

10. Audio Signal search box

Enter the search band in the search box and click the "Confirm" button on the right side to start searching, or click the "Auto search" button to search the audio signal automatically.

11. Audio Signal band list

Here displays the detected audio signal bands.

12. Clear button

Click this button to clear the detected audio signal bands.

Attention:

When performing Audio and Video signal detection, the audio and video frequencies should be fully detected, and each frequency should be detected in turn. You can click the Previous/Next button to switch to fully detect the frequencies of audio and video.

Camera Detection Interface

Click the Camera Detection module button  in the Quick Detection interface to enter the Camera Detection Module. The camera detection module integrates normal camera functions and infrared thermal imaging functions, users can use the corresponding functions according to the actual needs.

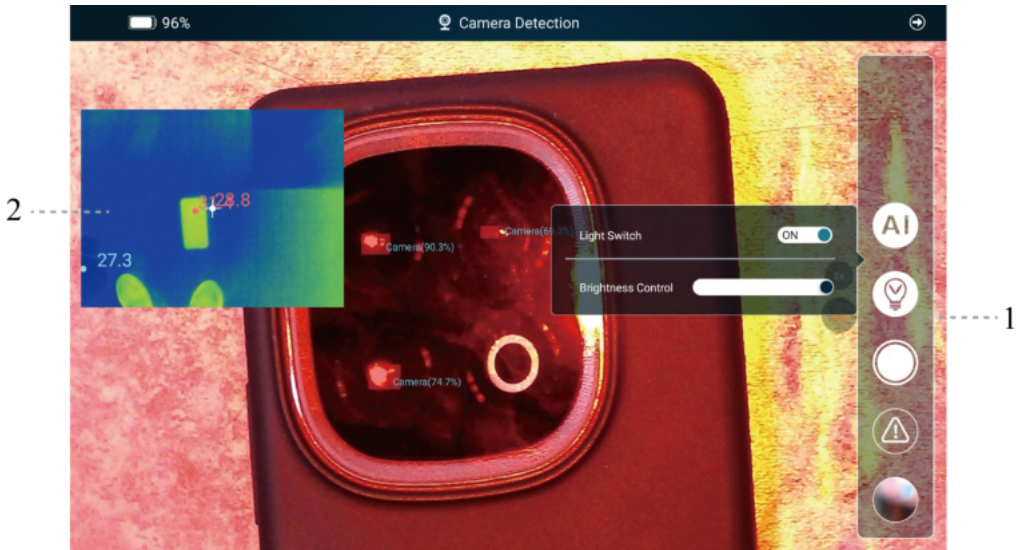

1. Camera Detection Settings Area

 : AI Assisted Recognition button, tap it and the bottom color of the icon turns white to indicate that AI Assisted Recognition is on. This function needs to be used with the camera light (camera light on).

 : Light Settings button, tap it to bring up the light settings options. Including camera Light Switch(on/off), Brightness Control.

 : Photo button, click to take photo.

 : Alarm setting button, click to pop up alarm option (buzzing/vibrate).

 : Click to enter camera detection album.

 : Screenshot multiplier switch button, click the corresponding button to switch the screen to double or triple.

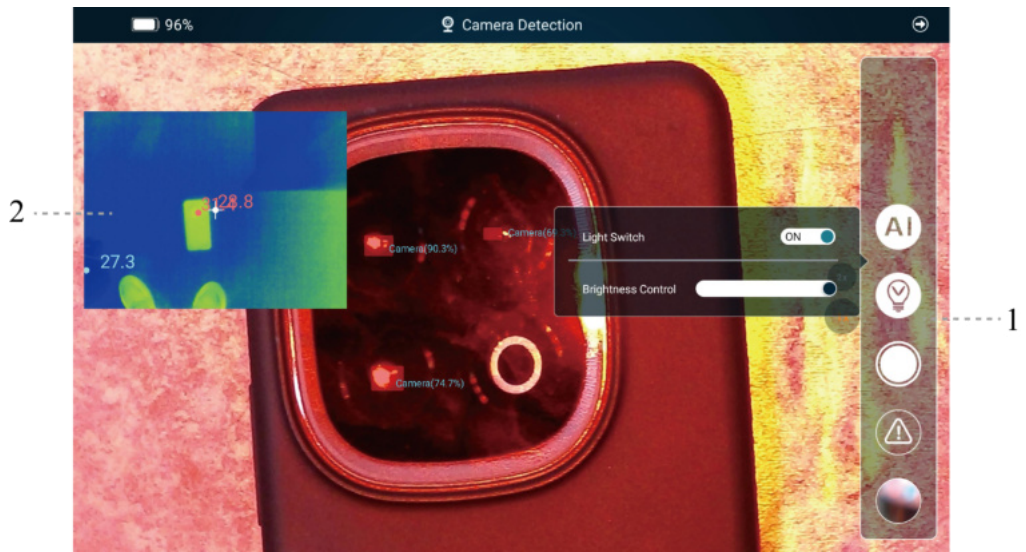

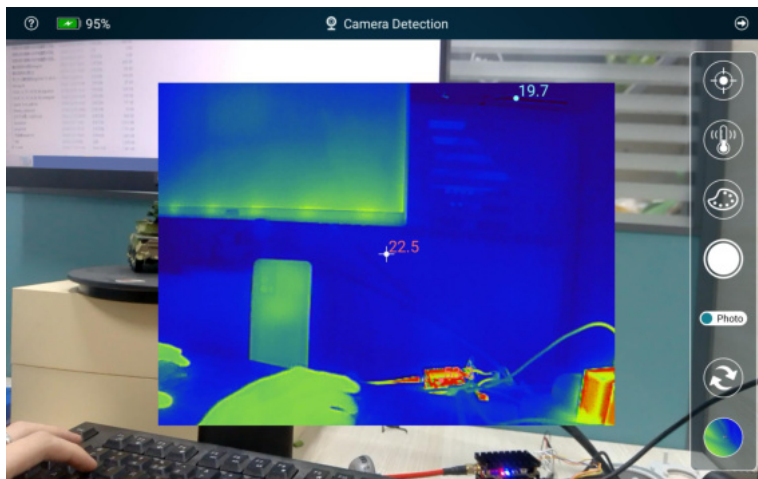

2. Thermal Imaging Mode Window

Click on this window to enter the Thermal Imaging Detection Mode.



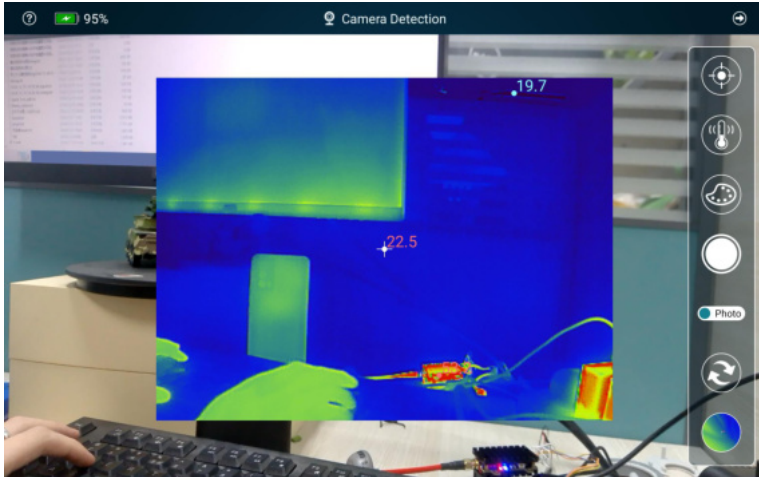

: Add Temperature Point button, click this button and then select the desired temperature point in the Thermal Imaging window.





 : Temperature alarm setting button, click the button to bring up the temperature alarm on/off and alarm temperature setting.

 : Thermal imaging window pseudo-color mode selection button, click the button, pop-up pseudo-color options, white hot/hot/rainbow.

 : Start/Stop button, click the button to start/stop photo or video recording.

 : Shooting mode switching button, click the button to switch the shooting mode to photo/video, here indicates that the current shooting mode is photo.

 : Temperature calibration button, click it to improve the quality of infrared image and calibrate the temperature of current temperature measurement point.

 : Click to enter the Thermal Imaging Detection Album.

Attention:

- When using Camera AI Assisted Recognition, please turn on the red light of the equipment and make sure that the red light of the equipment is shining into the environment under detect.
- When using Camera AI Assisted Recognition, please place the lens on the back of the equipment parallel to the object under detect.
- When using the camera, the equipment should not shake too much and focus on the subject for auto focus.

Endoscope Detection Interface

Click on the Endoscope Detection module button  in the Quick Detection interface to access the Endoscope Detection Module. To use this module, you need to connect an endoscope.

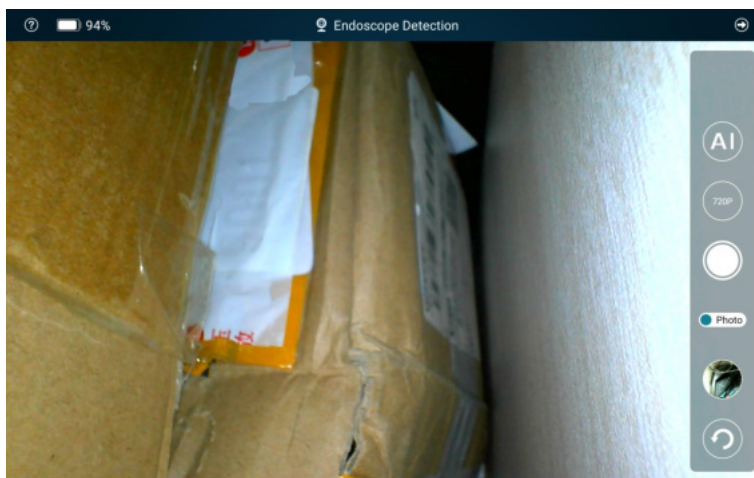

 : AI Assisted Recognition button, tap it and the bottom color of the icon turns white to indicate that AI Assisted Recognition is on.

 : Pixel setting button, tap it to bring up the pixel options. Selectable pixels 1920*1080/1280*720/640*480, here means the current pixel is 1280x720.

 : Start/Stop button, click to start/stop photo or video recording.

 : Shooting mode switch button, click the button to switch the shooting mode to photo/video, here it means the current shooting mode is photo.

 : Click to enter the endoscope detection photo album.

 : Rotate button, click the button to rotate the current lens screen by 180° .

Attention:

When using the endoscope for detection, avoid stressing the port to avoid loose contact and interruption of the screen.

Nonlinear Junction Linkage Detection Interface

Click on the Nonlinear Junction Linkage Detection module button  in the Quick Detection interface to enter the Nonlinear Junction Linkage Detection Module. (This function needs to be used in conjunction with the nonlinear junction detector)

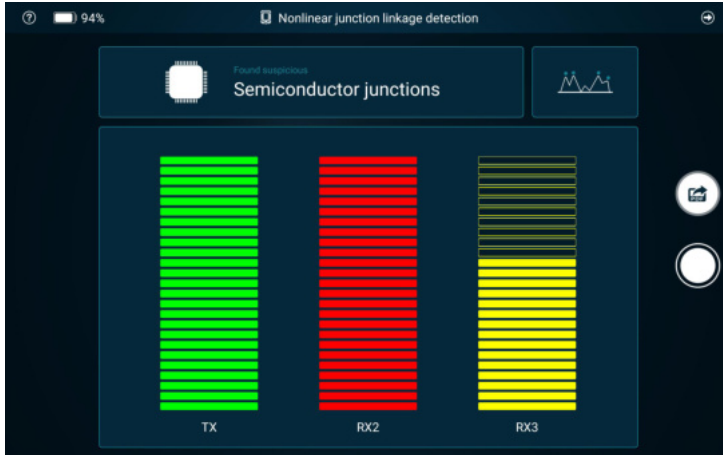

The detection results will be displayed in real-time at the top of the interface, and user can enter the real-time detection results interface by clicking the Historical Detection Records button .

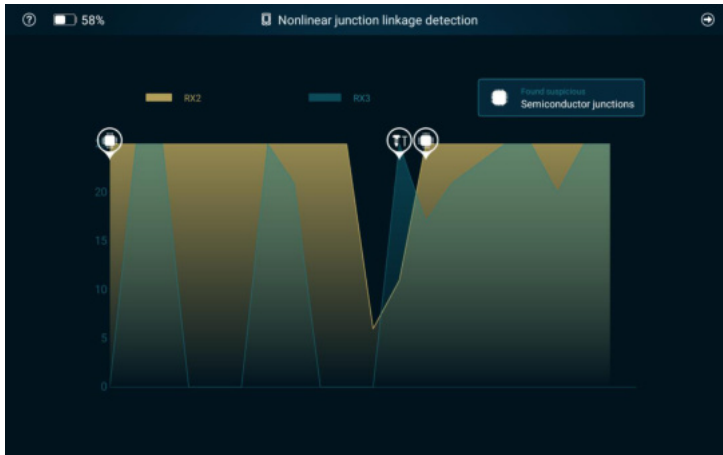

Process Detection Interface

Click the Process Detection button from the bottom task bar of the system homepage to enter the process detection interface. The first step of process detection requires the creation of tasks and rooms, users enter the task name, room name and click on the "Start Detection" button to enter the next step interface.

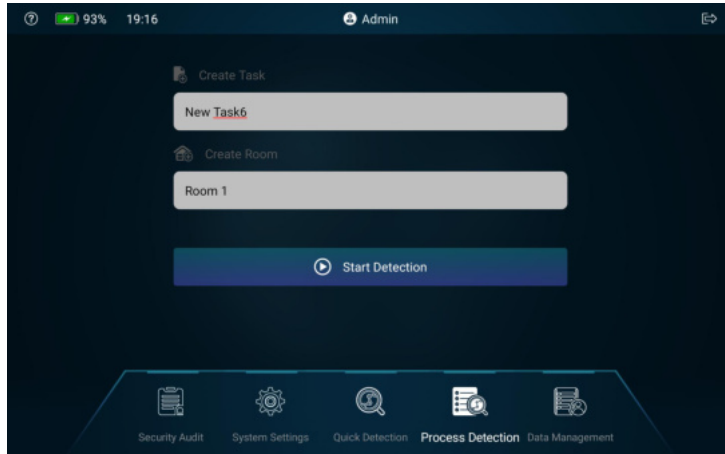

Detection modules are displayed in the list in the lower level interface, and the user can start the detection by clicking "Pending Detect". Users can select all modules to be detected or select individual modules to be detected. Detection data is arranged in thumbnail format, users can click on the thumbnail to view the data details, and click the "Complete" button at the bottom of the interface when the detection is completed.

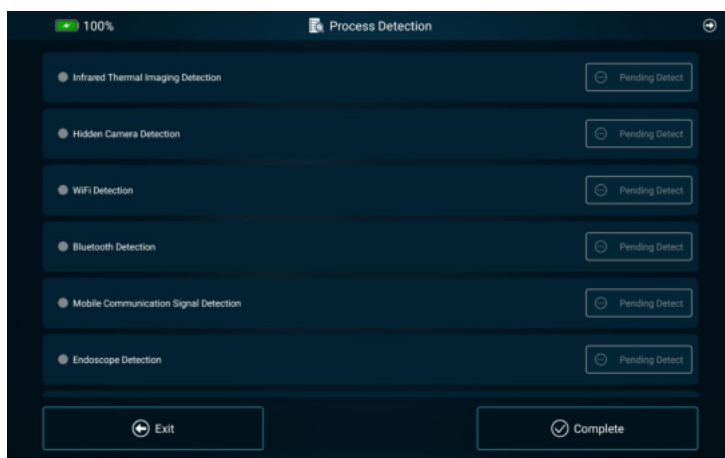

After clicking the "Complete" button, users can select the template for the detection report, set the header, footer, logo, etc., and sign to generate the detection report after the preview is correct. The interface of each detection module in Process Detection is similar to that of Quick Detection, so we won't repeat it here, users can check the chapter of Quick Detection interface.

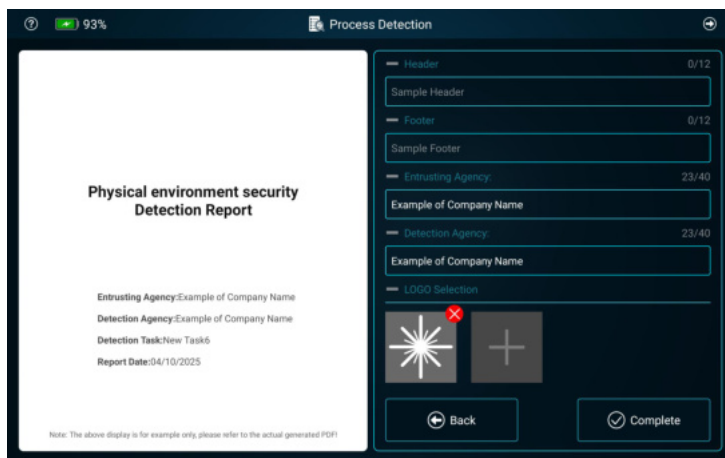
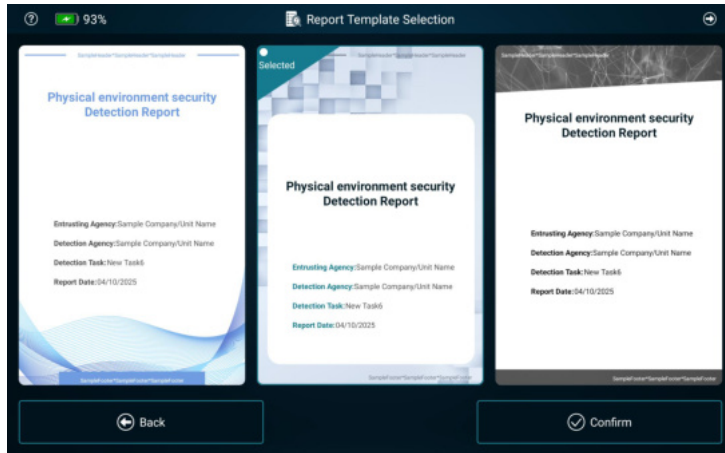

Users can click the Data Management button from the bottom of the home page to enter the Data Management interface to export the detection results in the form of PDF files.

System Settings Interface

Click the System Settings button from the bottom taskbar of the system homepage to enter the System Settings interface. The system setting interface includes Blacklist Management, Whitelist Management, Date and Time Settings, Screen Rest Time Setting, Screen Brightness Adjustment, Volume Control, Geomagnetic Calibration, APP Upgrade, and About. Users can click on the corresponding items and complete the corresponding operations according to the interface prompts.

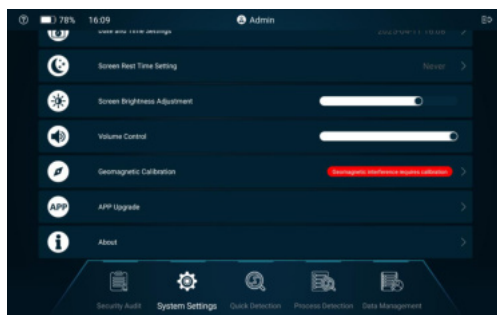
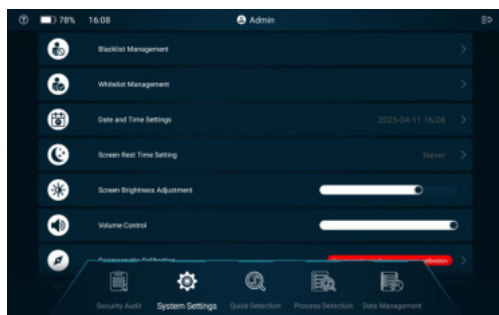

How to Upgrade APP :

1. Place the APK of the new version of the app in the root directory of the USB flash drive (the original name of the APK should not be changed)
2. Connect the USB flash drive to the main unit.
3. Click "APP Upgrade" and complete the automatic upgrade according to the interface prompts.

Security Audit Interface

Click the Security Audit button from the bottom taskbar of the system homepage to enter the Security Audit interface. In the Security Audit interface, the system administrator can modify the account password, reset the password, unlock the account, set the remaining storage space alarm capacity and capacity alarm switch of the equipment. Log storage period setting privileges and audit log viewing privileges are only open to auditors and system administrators.

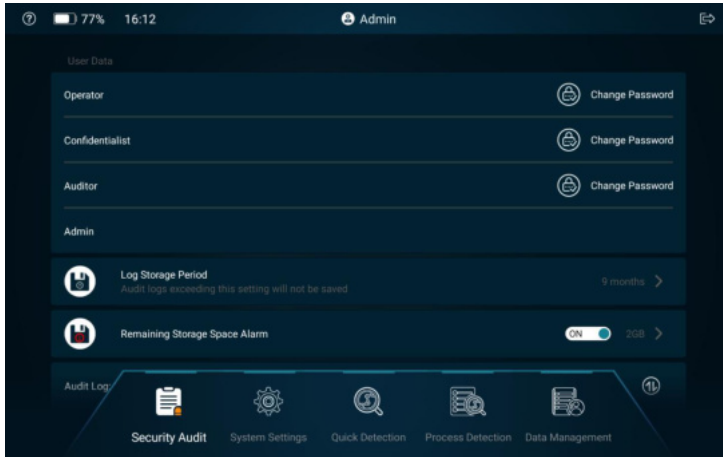

Attention:

- Freeze: If the same account (except the system administrator) enters an incorrect password 5 times in a row, the account will be frozen and the system administrator is required to unlock the account.
- Unlock: Using the system administrator account, enter the security audit interface. In the account list, left slide the specified account to unlock the account.
- Forgot Password: Using the system administrator account, enter the security audit interface. In the account list, swipe left to specify the account to reset the password.

Data Management Interface

Click the Data Management button  from the bottom taskbar of the system homepage to enter the data management interface. The detection data format is image, video, PDF, and you can preset PDF report format, make regular data comparison (monthly and annual detection report can be generated), view the detection data, and export the detection data.

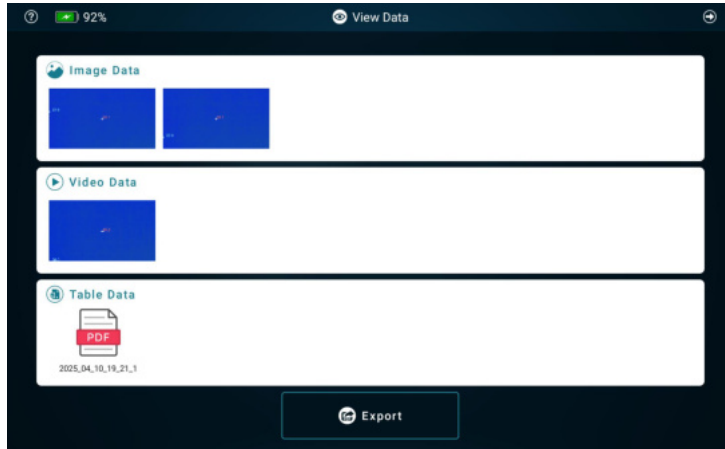
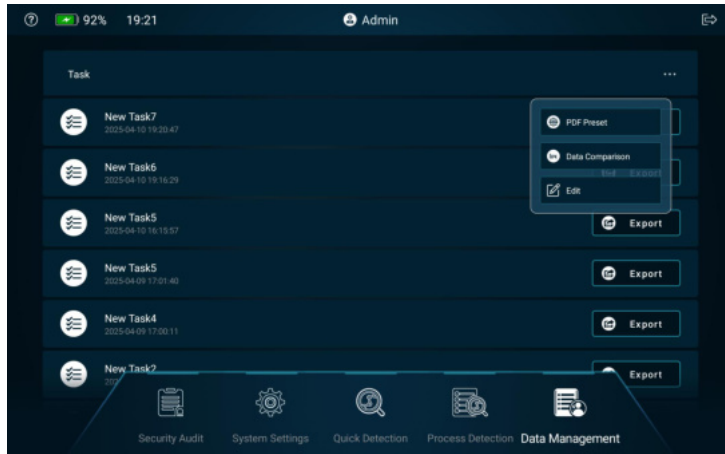

How to Use

Power On

Take out the main unit, endoscope, user manual and charger in turn after opening the carrying case.

Long press the mainframe on/off button for 3 seconds to turn on the equipment, the power indicator lights up, and open the antenna cover of the main unit. Tap the account icon and enter the password to enter the Quick Detection interface (home page). For each account authority and password.



Tracking Compass Geomagnetic Calibration

Users need to calibrate the tracking compass manually when they use the equipment for the first time or when the equipment is stationary but the sector on the tracking compass (the area pointed out by the equipment) keeps drifting, there are two ways to calibrate the tracking compass manually:

1. Click the System Settings button on the home page to enter the System Settings interface, click "Geomagnetic Calibration" and then swing the equipment along the inverted 8-character (∞) track to complete the calibration.
2. Click any Track button in the Wireless Signal Detection interface to enter the tracking interface, if the accuracy of the tracking compass is out of order, the system automatically pops up a calibration prompt window, click to confirm the handheld equipment along the inverted 8 words (∞) trajectory swing to complete the calibration.

You can refer to the following calibration operation steps:

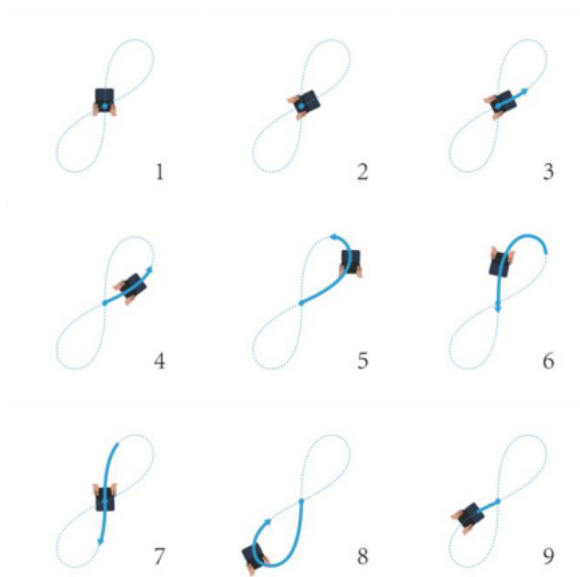

WiFi Detection

WiFi detection is used to detect eavesdropping and photo-tapping devices transmitted via WIFI.

1. Click the Wireless Signal Detection module button and then click the WiFi button in the Quick Detection interface, or click "WiFi Detection > Pending Detect" in the Process Detection to open the Detection window.
2. In the WiFi detection interface, you can see the number of hotspots, terminal devices and suspicious devices in the surrounding environment, the signal topology list, and the signal strength list. The topology map and the signal list on the right side have linkage function, click any network name or MAC address in the topology map, the network/device will be displayed in the signal list on the right side with linkage.
3. When a device is identified as a suspicious device, click the Track button in the device list to view its specific information and tracking location.
4. Entering the tracking interface, you can manually mark the device as suspicious. The device will be listed in the first line of the WiFi detection interface, and detailed information of the device will be listed in the security detection report.
5. You can use the tracking method of proximity localization to move the equipment in any direction, and when the alarm sound becomes more and more rapid, it indicates that it is getting closer and closer to the suspicious device.

Bluetooth Detection

Bluetooth detection is for detecting suspicious Bluetooth terminals.

6. In the Quick Detection interface, click the Wireless Signal Detection module button and then click the BT button on the right side, or click "Bluetooth Detection > Pending Detect" to open the detection window in the Process Detection.
7. In the Bluetooth detection interface, you can see the total number of Bluetooth devices in the surrounding environment, the number of suspicious devices, the detection status, the signal name, the manufacturer's information and the MAC address.
8. When you identify a device is suspicious, click the Track button to enter the Bluetooth tracking interface, you can manually mark it as a suspicious device, which will be listed in the first line of the Bluetooth signal detection interface in an eye-catching form, and the detailed information of this device will be listed in the security detection report.
9. You can use the tracking method of proximity localization to move the equipment in any direction, and when the alarm sound becomes more and more rapid, it indicates that it is getting closer and closer to the suspicious device.

Mobile Communication Signal Detection

Mobile communication signal detection is mainly for the detection of eavesdropping and photo-tapping devices transmitted through mobile signals.

1. In the quick detection interface, click the Wireless Signal Detection module button and then click the Mobile signal button, or click "Mobile Communication Signal Detection > Pending Detect" to open the detection window in the process detection.
2. After entering the Mobile Communication Signal Detection, the left side displays the sensitivity adjustment button and the mobile communication signal classification detection; the right side displays the signal strength list, the signal classification sorting, the signal strength sorting, the frequency management, the data reset and other buttons.
3. When a signal is identified as a suspicious signal, click the Track button to enter the mobile communication signal tracking interface. The device can be marked as suspicious manually. The device will be listed in the first line of the Mobile Communication Signal Detection interface in a conspicuous form, and the detailed information of this device will be listed in the security detection report.
4. You can use the tracking method of proximity localization to move the equipment in any direction, and when the alarm sound becomes more and more rapid, it indicates that it is getting closer and closer to the suspicious device.

Audio and Video Signal Detection

The audio and video signal detection function can detect eavesdropping and photo-tapping devices transmitted through analog signals.

1. Select the Wireless Signal Detection module button and then select the FM button in the Quick Detection interface, or click "Audio and Video Signal Detection > Pending Detect" in the Process Detection to open the detection window.
2. After entering the audio and video signal detection interface, the upper half of the screen shows analog video signal detection, when detecting click on the Auto Search button, the equipment can automatically search for the corresponding frequency, if there is an analog signal transmission of video signals, it will be automatically presented in the right box. The lower half of the screen shows the FM audio signal detection, and you can manually mark suspicious audio signals.

Hidden Camera Detection

Hidden camera detection is mainly used for pinhole camera detection.

1. Click the Camera Detection module button in the Quick Detection interface, or click "Hidden Camera Detection > Pending Detect" in the Process Detection to open the detection window.
2. After entering the detection interface, point the equipment camera at the target area to start detection. When there is a lens in the screen, the location of the lens will be marked automatically with a blue frame.
3. The hidden camera detection interface allows adjustment of the red light brightness and alert mode. Before detection, you need to turn on the AI Assisted Recognition function and light, and set the alarm mode.



Infrared Thermal Imaging Detection

The main purpose of infrared thermal imaging detection is to detect abnormal heat sources.

1. Click on the infrared thermal imaging window in the Camera Detection interface or click on "Infrared Thermal Imaging Detection> Pending Detect" in the process detection to open the infrared thermal imaging detection window.
2. After entering the detection interface, point the camera at the target area and start detecting, you can see the thermal imaging area on the screen, and different temperatures are indicated by different colors. The right menu bar can be set to increase the temperature measurement point, temperature alarm, pseudo-color mode, photo, temperature calibration, photo album button, the photo can be used to generate reports.

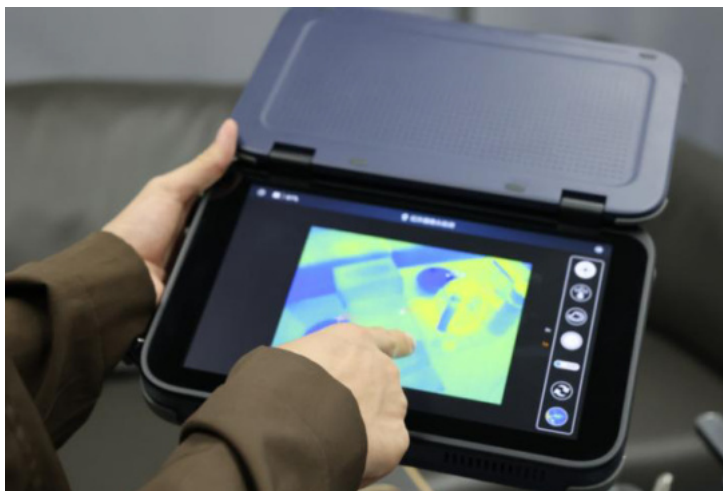

Endoscope Detection

Endoscope detection is used to detect eavesdropping and photo-tapping devices hidden in pipelines, holes and slits, lamp slots and other special environments.

1. Tap the Endoscope Detection module button in the Quick Detection interface, or click "Endoscope Detection > Pending Detect" in the Process Detection interface to enter the detection interface.
2. Before detection, connect the endoscope to the equipment, extend the endoscope into the pipeline, toggle the wheel on the endoscope, adjust the brightness of the endoscope light, and then you can view whether there is a camera in the pipeline on the equipment in real time.
3. When detecting, you can choose to open the AI Assisted Recognition function, after opening the endoscope will automatically frame the alarm after detecting the object suspected of being a camera, and when you find the suspicious object, you can click to take pictures or video forensics, and you can view it in the photo album or detection report.



Nonlinear Junction Linkage Detection

Portable Integrated TSCM Equipment can be linked with the nonlinear junction detector to record and retain the detection data of the nonlinear junction detector, and the detecting data will be reflected in the final generation of the detection report.

1. When using, first point the head end of the nonlinear junction detector to the target area. After the nonlinear junction detector detects the abnormality, connect the nonlinear junction detector to the main unit via USB cable.
2. Select the Nonlinear Junction Linkage Detection module button in the Quick Detection interface, or click "Nonlinear Junction Detection > Pending Detect" in the Process Detection interface to enter the detection interface. The detection interface can display the same alarm information as the head end of the nonlinear junction detector.
3. Data retention can be accomplished by taking a photo of the actual scene through the Portable Integrated TSCM Equipment.



Export Detection Report

When you are detecting wireless signals, you can click the Export Data button in the interface to export the detection data instantly. Or click the Data Management button on the status bar at the bottom of the home page to enter the Data Management interface and export the detection report.

Screen Switch

Close the main unit antenna cover or click the on/off button to turn off the screen; open the main unit antenna cover or click the on/off button to wake up the screen automatically. The equipment will turn off automatically after one hour of continuous screen off.

Equipment Charging

Take the charger out of the lower part of the carrying case, connect it to the USB-C port of the main unit, turn on the power, the main unit charging indicator will light up red, and the equipment will start charging.



Power Off

After completing the detection, press and hold the on/off button for 3 seconds, tap the "Power off" button on the screen, close the antenna cover of the main unit, and put the main unit, endoscope, charger, etc. back into the carrying case.

Troubleshooting

1. Unable to rest the screen or touch screen unresponsive

Long press the on/off button for 8 seconds to force power off; if it is invalid, press the reset button with the help of the card pin, and then reboot.

2. Cannot connect the external module

- Please make sure whether it is plugged into port A.
- Please re-plug the port.

3. Function module is loading all the time

- Please exit and enter the function again.
- Please reboot the equipment.

4. The temperature displayed in the infrared thermal imaging mode deviates greatly from the actual temperature.

Please click the temperature calibration button and wait for 2 seconds to return to normal.

5. WiFi device cannot be detected

- Please wait patiently for 1~3min, it takes some time to detect.
- Exit the detection interface and enter the WiFi detection module again to detect.
- Please make sure the WiFi device is in working condition.

6. Bluetooth device cannot be detected

- Please confirm whether this Bluetooth device is in broadcasting status.
- Exit the detection interface and enter the Bluetooth detection module again for detection.

7. Cannot detect mobile device

- Try to change different detection sensitivity for detection.
- Please make sure whether you are too close to the base station, which has a large field strength.
- Please do not detect outdoor.

8. The infrared camera has no screen and keeps displaying -271°C-

- Please wait for the IR function to re-initialize, this process takes about 15 seconds.
- please click the temperature calibration button and wait for 2s to return to normal.
- Please exit and enter the function again, or restart the equipment and enter again.

9. No image on the camera.

Please exit and enter the function again, or restart the equipment and enter again.

10. WiFi/Bluetooth signal strength is not updated.

- Please click the data reset button and detect again.
- Please make sure the WiFi/Bluetooth device is in working condition.

11. Unable to charge

- Please use the original charger to charge.
- Please make sure whether it is plugged into USB-C port.

12. Cannot login

Please check if the password is correct and the account is not in a frozen state.

Maintenance

1. Before cleaning the equipment, please turn off the equipment and wait for the equipment to cool down.
2. Clean the equipment regularly, turn off the equipment before cleaning, use clean dust-free cloth or towel to wipe the equipment, prohibit the use of alcohol and other organic solvents.
3. When the equipment is not working, close the cover, turn off the screen or shut down the equipment.
4. When the equipment is in use, avoid falling, squeezing, collision equipment to avoid scratches.
5. When the equipment is idle, the equipment should be turned off and put back into the carrying case.
6. When the equipment is not used for a long time, the battery should be charged once every 3 months to 40%-60% of the power can be charged to avoid low power damage to the battery.