



# No Touch Exit Sensor

k1-1 / k1-2

## Features & Application

No touch / Touch free Exit Sensor (Diffused Detection)  
 Optical / Infrared Technology  
 IP-55 Ingress Protection / SUS 304 Stainless steel Plate  
 User friendly (Healthy protection):  
 Free from contagious diseases spread  
 Detection range: 0.1 ~ 10 cm  
 Application: Gate/Door/Exit/Automation control

High capacity of relay dry contact (3A/AC120V,DC30V)  
 Normally open/Normally close/Common relay output  
 Twin led indicators for sensor standby or approached:  
 (1) Sensor Standby: BLUE LED ON  
 (2) Visitors whom approached to the sensor in 10 cm:  
 RED LED ON

## Included

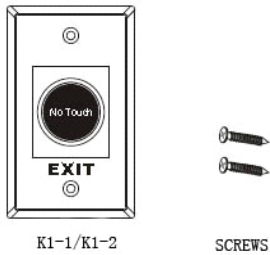

## Specifications

Contact Rating: 3A/AC120V,DC30V  
 Input Volt.: DC 12V  
 Simple and clear for operation.  
 Operation temperature range -20° C 55° C  
 Life: 500,000 Times  
 Durable stainless steel plate  
 Dimension: 115x70x29(mm)  
 Weight: 85g

## Dimensions & Part Account

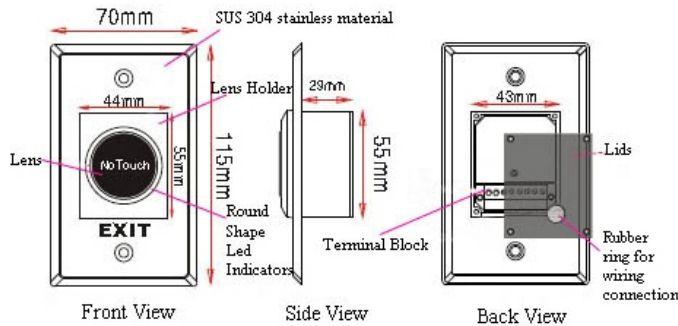

## Wiring Connection

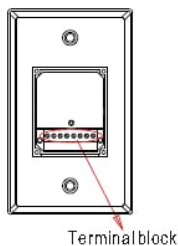

K1-1: (5 Pins)

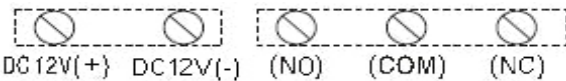

K1-2: (8 Pins)

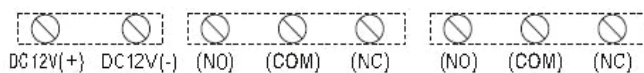

## Installation



## Sensing Range

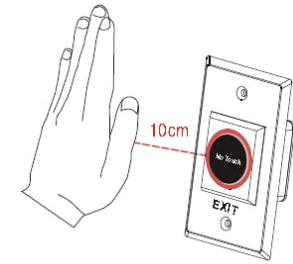

## LED Indicator



A: Black / PC Lens  
 B: Round Shape LED Indicator

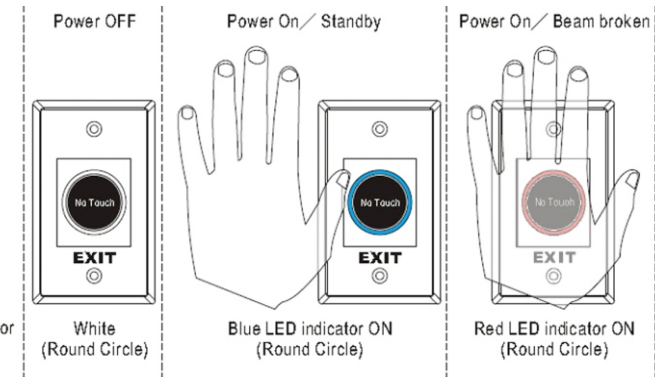

## Example

The cable of the connected with the no touch exit sensor, access control machine and electrical bolt

