

Quick Start Guide

2.4 Inch TFT Terminal

Version: 1. 0

1 Overview

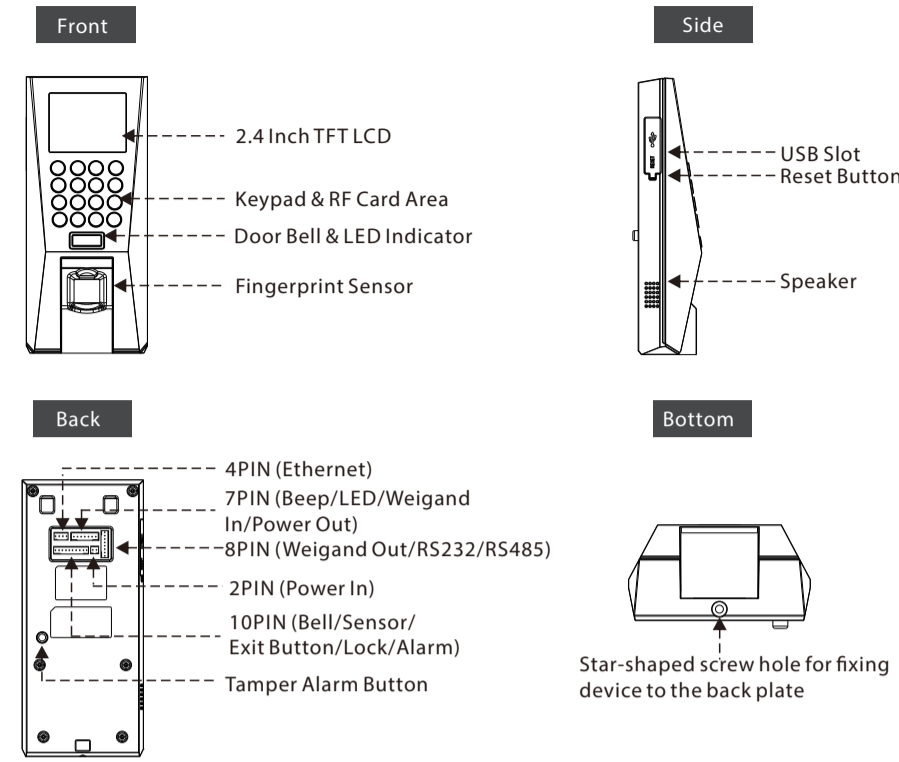

2 Installation of Wall-mount

Before the installation, please connect the cables to the connectors.
 1) Fix back plate to the wall. 2) Mount the device on the back plate.
 3) Secure the device and back plate.

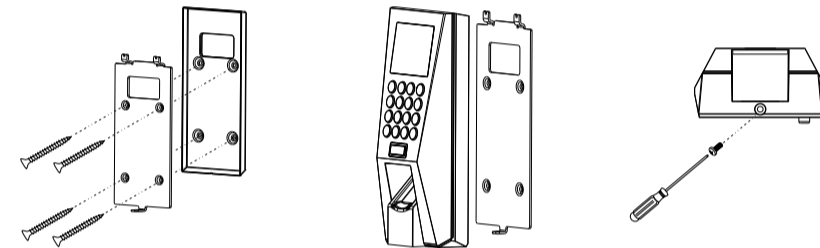

1

3 Cautions

- 1) Power cable is connected after other wirings, and shut down the power firstly, when making some necessary checking.
- 2) We recommend that use the DC 12V/3A power supply.
- 3) Please read the terminals description carefully and wiring by rule strictly.
- 4) Please connect the GND before other wirings especially under the serious electrostatic environment.
- 5) Do not install the device in a place subject to direct sun light, humidity or dust.

4 Wiring Diagram

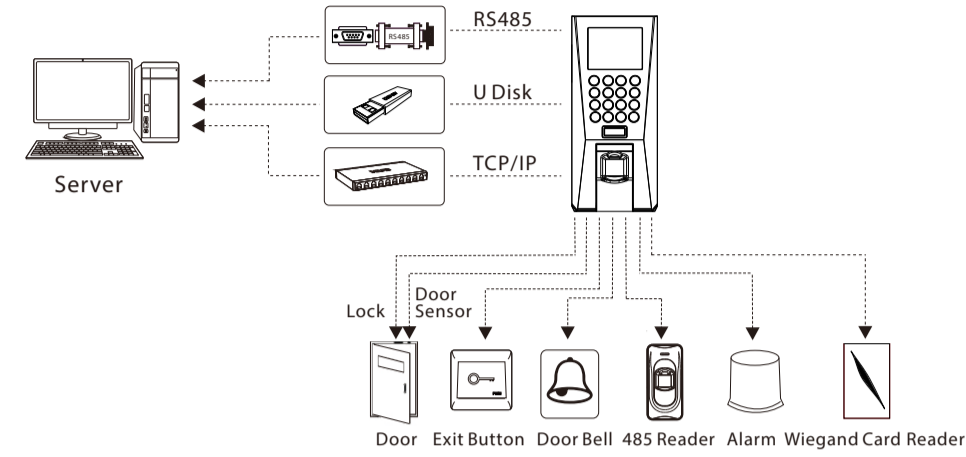

5 Lock Connection

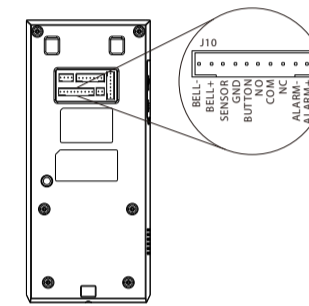

PIN	Description	Color
1	Bell BELL-	Purple
2	Bell BELL+	Brown
3	Sensor SEN	White
4	Ground GND	Black
5	Button BUT	Gray
6	Normal Open NO1	Blue
7	COMM COM1	Red
8	Normal Close NC1	Yellow
9	Alarm AL-	Orange
10	Alarm AL+	Green

2

Device Shares Power with the Lock

Device shares power with the lock:
 $U_{lock} = 12V, I_{lock} > 1A$ and the distance between the lock and the device is equal or less than 10 meters.

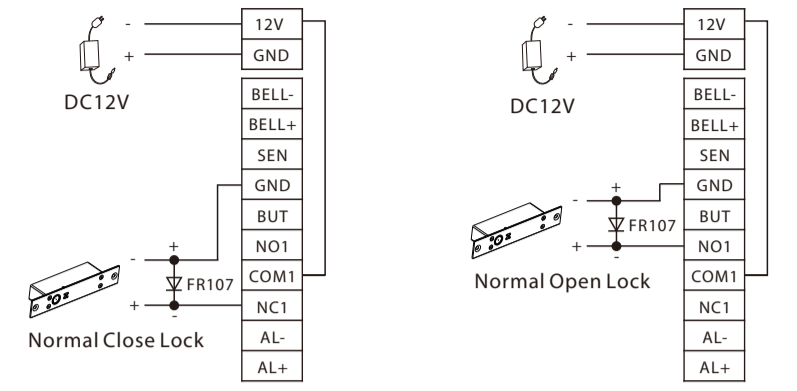

Device does not Share Power with the Lock

- A. $U_{lock} = 12V, I_{lock} \leq 1A$
- B. $U_{lock} \neq 12V$
- C. The distance between the lock and the device is more than 10 meters.

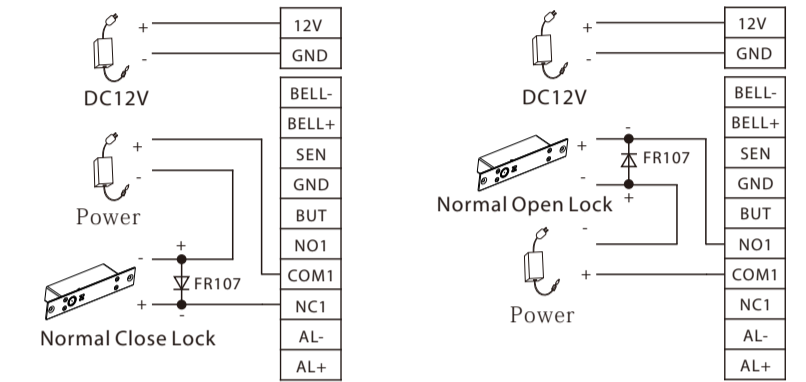

'I': device output current 'U_{lock}': lock voltage 'I_{lock}': lock current

(1) The system supports NO LOCK and NC LOCK. For example the NO LOCK (normally open at power on) is connected with 'NO' and 'COM' terminals, and the NC LOCK (normally close at power on) is connected with 'NC' and 'COM' terminals.

(2) When the Electrical Lock is connected to the Access Control System, you must parallel one FR107 diode (equipped in the package) to prevent the self-inductance EMF affecting the system. **Do not reverse the polarities.**

3

6 Door Bell & Door Sensor & Exit Button & Alarm Connection

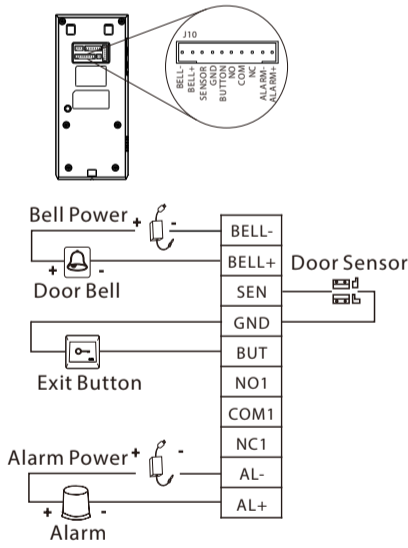

PIN	Description	Color
1	Bell BELL-	Purple
2	Bell BELL+	Brown
3	Sensor SEN	White
4	Ground GND	Black
5	Button BUT	Gray
6	Normal Open NO1	Blue
7	COMM COM1	Red
8	Normal Close NC1	Yellow
9	Alarm AL-	Orange
10	Alarm AL+	Green

7 Wiegand Card Reader Connection

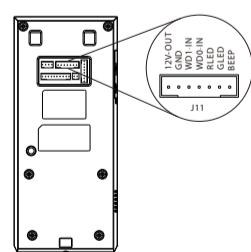

PIN	Description	Color
1	Power Out +12V	Red
2	Ground GND	Black
3	Wiegand In IWD1	White
4	Wiegand In IWD0	Green
5	Red LED RLED	Blue
6	Green LED GLED	Gray
7	Beep BEEP	Purple

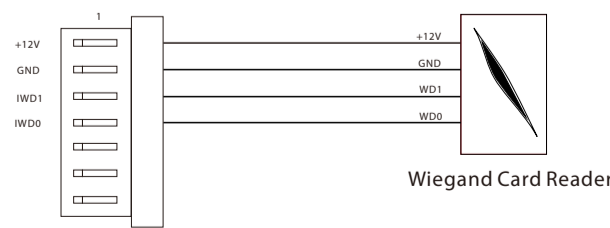

4

8 485 Reader Connection

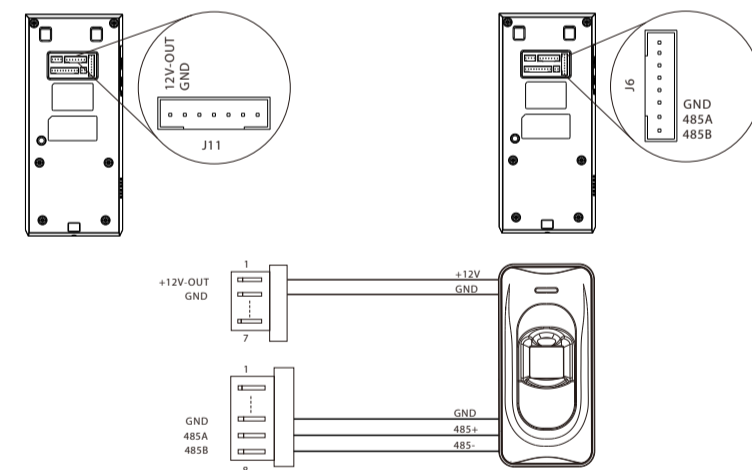

How to enable 485 Reader Function?

1. Disabled RS485 and RS232 Function: Press M/OK > Comm. > Serial Comm > RS485 and RS232, select OFF to disable RS485 and RS232 Function.
2. Enable 485 Reader Function: Press M/OK > Access Control > Access Control Options > 485 Reader, choose master unit or slave unit.

9 Communication with PC Via Ethernet Cable

To connect device with a PC directly, connect both devices with a straight network cable. Such as the following figure.

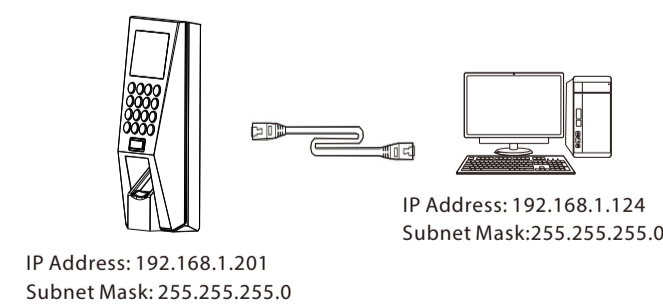

5

10 Power Connection

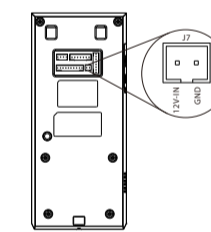

PIN	Description	Color
1	Power In +12V	Red
2	Ground GND	Black

Recommended power supply:
 12V ± 10%, at least 500mA.
 To share the power with other devices, use a power supply with higher current ratings.

11 Date/Time Setting

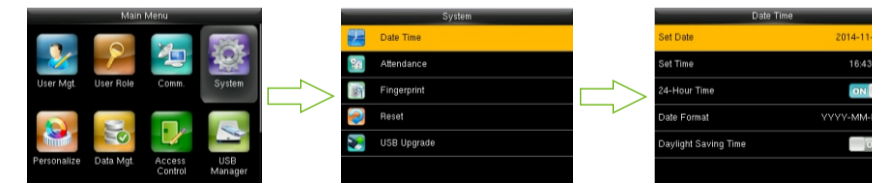

Press M/OK > System > Date Time to enter the Date Time interface.

12 Adding a User

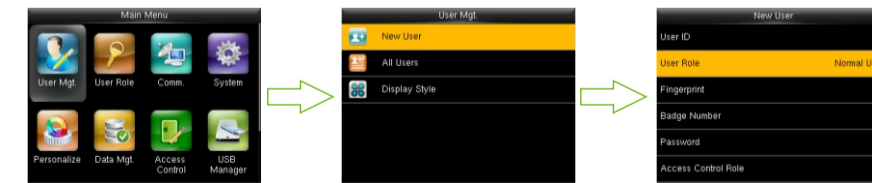

Press M/OK > User Mgt. > New User to enter the New User interface.
 The setting include entering a name, modifying user roles (Super Admin / Normal User), enrolling a fingerprint, enrolling an ID card, enrolling a password, modifying access control role.
 Adding a Super Admin: Select Super Admin in User Role to add a super admin.
 Adding a Normal User: Select Normal User in User Role to add a normal user.

13 Ethernet Setting

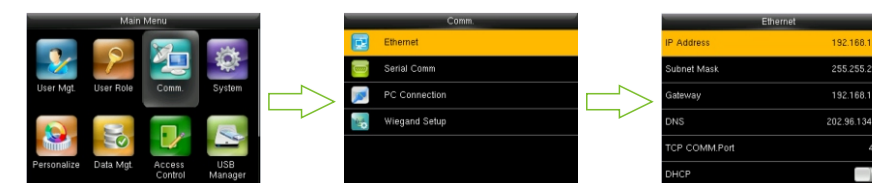

Press M/OK > Comm. > Ethernet to enter the Ethernet interface.

6

14 Access Control Setting

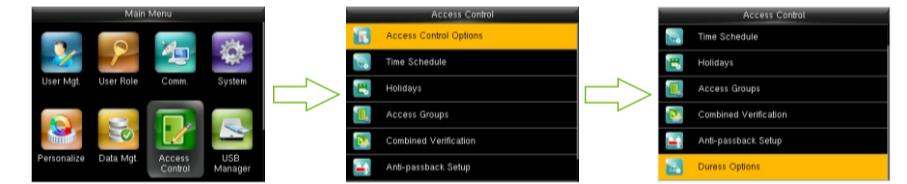

Press M/OK > Access Control to enter the Access Control interface.
 To unlock, the enrolled user must accord with the following conditions:
 1) The current unlock time should be in the effective time of user time zone or group zone.
 2) The group which user is must be in Combined Verification.

Access Control Options: Set parameters to control locks and related device.
 Time Zone: It is the minimum unit of access control option.
 Holidays: Set some days as holidays, and then set Time Schedule of those days.
 Access Groups: Grouping is to manage employees in groups. Employee in groups use group time zone by default. Group members can also set user time zone.
 Combined Verification: Make various groups into different access controls to achieve multi-verification and improve security.
 Anti-pass Back: To prevent someone following the employee into the company.
 Duress alarm parameter: The device will open the door as usual, but the alarm signal will be sent to backstage alarm when employee comes across duress.

15 Disabled Slide Show

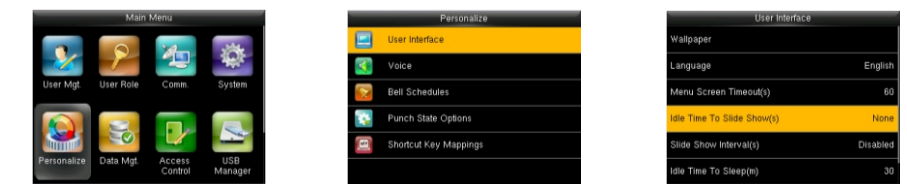

Press M/OK > Personalize > User Interface, set Idle Time To Slide Show(s) to be None, or set Slide Show Interval(s) to be disabled.

16 Trouble shooting

- 1) Fingerprint cannot be read or it takes too long.
 - Check whether a finger or fingerprint sensor is stained with sweat, water, or dust.
 - Retry after wiping off finger and fingerprint sensor with dry paper tissue or a mildly wet cloth.
 - If a fingerprint is too dry, blow on the finger and retry.
- 2) Fingerprint is verified but authorization keeps failing.
 - Check whether the user is restricted by door zone or time zone.
 - Check the user role is permissible.
 - Check the lock connection is corrected.
- 3) Authorized but door does not open.
- 4) When the device is tampered, the device will send a signal to the speaker then the icon is displayed on the top right corner and the speaker is ringing. Only the [Speaker Alarm] (Access Control > Access Control Options > Speaker Alarm) is [ON] can user heard the ringing.
 - Please install the device properly.

7