

MA300-IP65 Installation Guide

Version: 2.0

Date: December, 2013

1. Equipment Installation

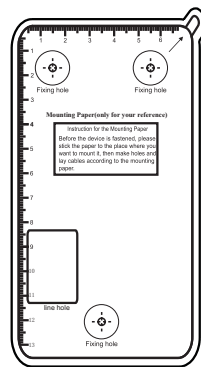

(1) Post the mounting template on the wall. Drill the holes according to the marks on the template (holes for screw and wiring).

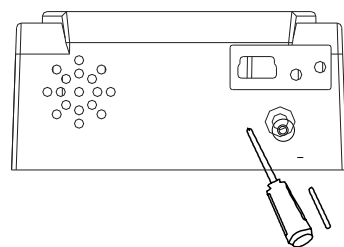

(2) Remove the screw on the bottom of device.

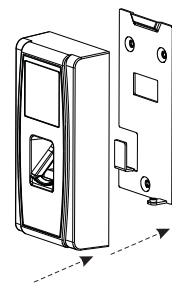

(3) Take away the back cover.

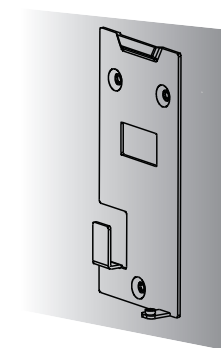

(4) Fix the back cover on the wall according to the mounting paper.

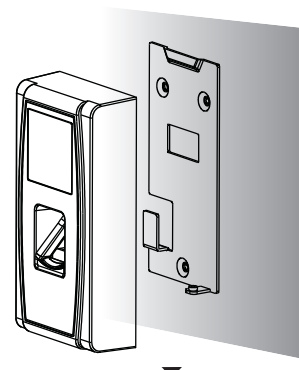

(5) Fix the device to the back cover.

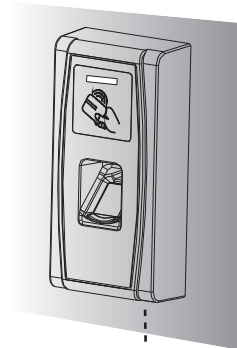

(6) Fix the screw.

2. Structure and Function

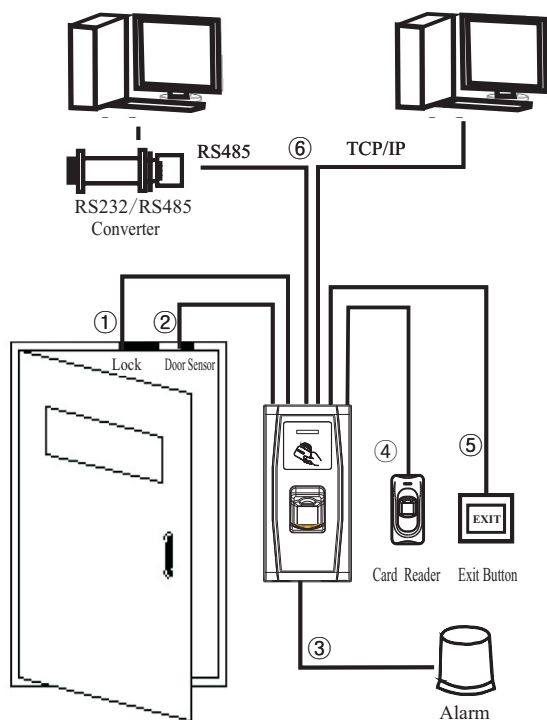

Access Control System Function:

- (1) If a registered user verified, the device will export the signal to unlock the door.
- (2) Door sensor will detect the on-off state. If the door is unexpected opened or improperly closed, the alarm signal (digital value) will be triggered.
- (3) If the device being illegally removed, the device will export alarm signal.
- (4) External card reader is supported.
- (5) External exit button is supported; it is convenient to open the door inside.
- (6) Supports RS485, TCP/IP modes to connect with PC. One PC can manage multiple devices.

Warning: No operating with power on!

3. Lock Connection

- (1) The system supports NO LOCK and NC LOCK. For example the NO LOCK (normally open at power on) is connected with 'NO' terminal, and the NC LOCK is connected with 'NC' terminal.
- (2) When the Electrical Lock is connected to the Access Control System, you need to parallel one FR107 diode (equipped in the package) to prevent the self-inductance EMF affect the system, do not reverse the polarities.

(I) Share power with the lock:

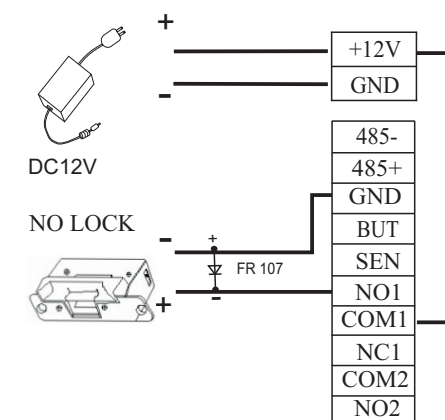
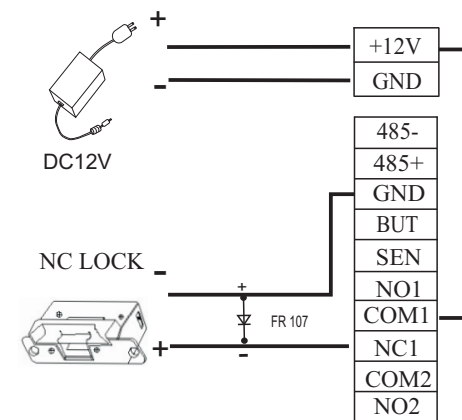

Device share power with the lock:
 $U_{LOCK}=12V, I_{-LOCK}>1A$ ①
 And the lock is near to the device.

(II) Does not share power with the lock:

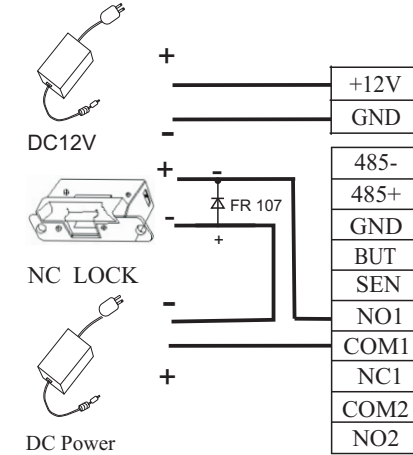
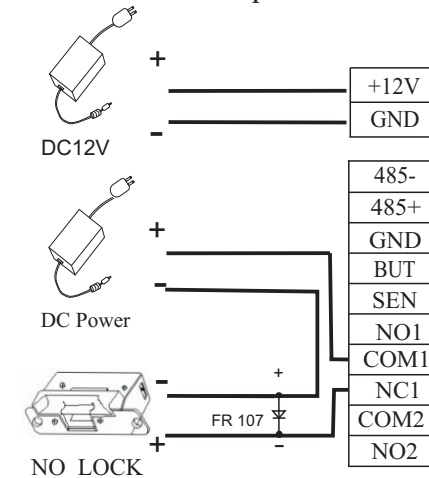

Device does not share power with the lock:
 A. $U_{LOCK}=12V, I_{-LOCK}\leq 1A$;
 B. $U_{LOCK}\neq 12V$;
 C. The lock is far apart from the device.

①: 'I': device output current, 'U_{LOCK}': lock voltage, 'I_{LOCK}': lock current.

4. Connected with Other Parts:

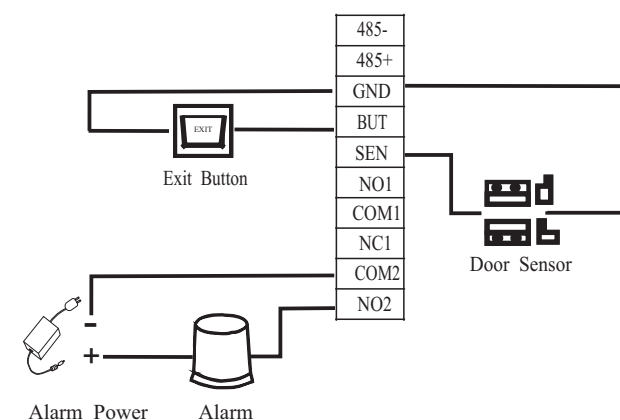

Voltage output \leq DC 12V for Alarm

5. Connected with Power:

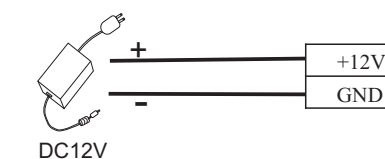

Input DC 12V, 500mA (50mA standby)
 Positive is connected with '+12V', negative is connected with 'GND' (do not reverse the polarities).

6. Wiegand Output

The device supports standard Wiegand 26 output, as a reader device it has a very good compatibility.

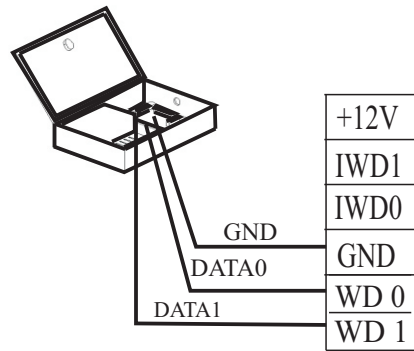

Notes:

- (1) Please keep the distance between the device and Access Control or reader less than 90 meters (Please use Wiegand signal extender in long distance or interference environment).
- (2) To keep the stability of Wiegand signal, connect the device and the Access Control or reader in same 'GND' in any case.

7. Wiegand Input

The device has the function of Wiegand signal input. It supports to connect with an independent reader. They are installed each side of the door, to control the lock and access together.

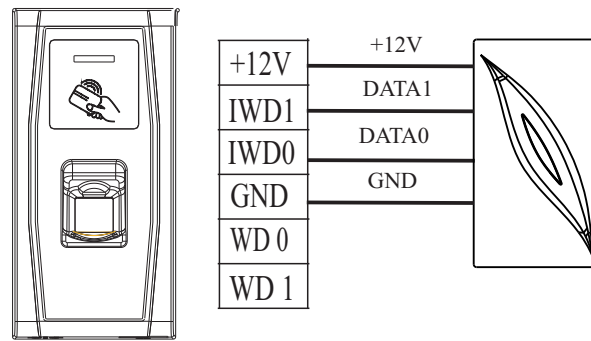

8. Other Functions:

(1) Manual Reset:

If the device does not work properly because of mis-operation or other abnormality, you can use 'Reset' function to restart it. Remove the black rubber cap, then stick the Reset button hole with a sharp tool (the tip diameter less than 2mm).

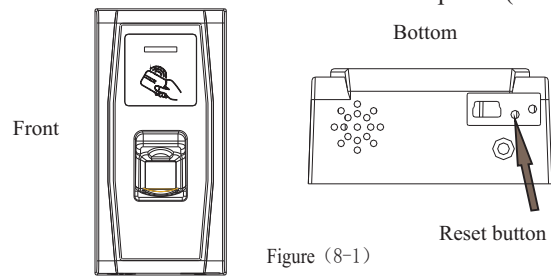

Figure (8-1)

(2) External USB Keyboard (Refer to your own keyboard):

The device supports external keyboard to offer more flexible operations. The keyboard need to purchase separately. It's convenient to enroll users, remove users, recovery factory settings, set the keyboard password and so on. The operation please refer to the user manual.

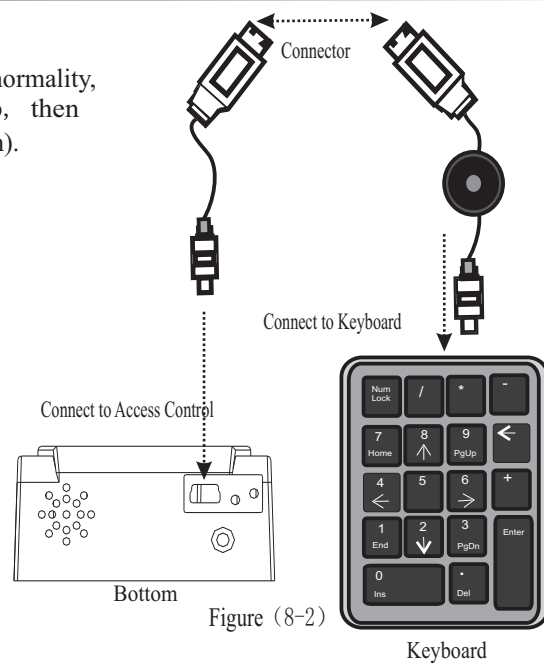

Figure (8-2)

(3) Recovery Factory Settings:

You can use the tamper switch (As figure (8-3)) to recovery factory setting, such as device number, system password, IP address, RS485 address, etc. More information please refers to the user manual.

Press the tamper switch three times after the alarm being triggered 30 seconds but no more than 60 seconds.

Note: The user data won't be cleared.

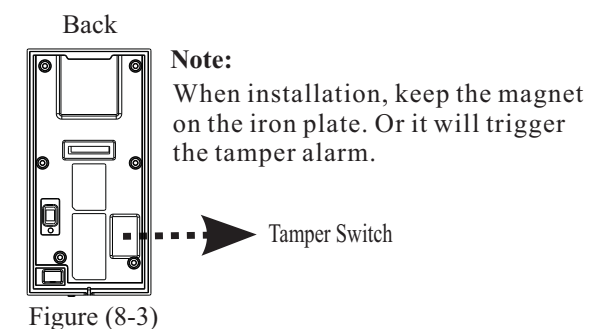

Figure (8-3)

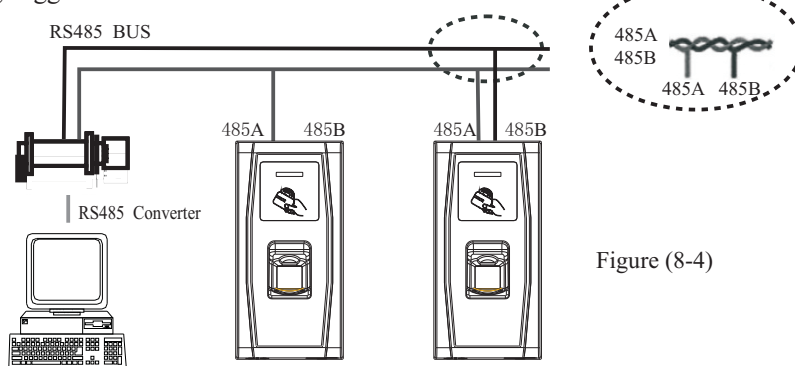

Figure (8-4)

9. Communication

There're two modes that the PC software communicate and exchange information with the device: RS485 and TCP/IP, they all support remote control.

1. RS485 Mode:

Please use specified RS485 wire, RS485 active converter and bus-type wiring.

Terminal	PC Serial Ports
485A	RS485 +
485B	RS485 -

- (I) To prevent the interference, the last device in the RS485 bus connect a 120 Euro resistor. That is turning the switch '4' (terminal resistor switch) to 'ON'.
- (II) The RS485 device No. is shown in PC software. You can change it as follows. (The default switch state is 'OFF').

Machine No.	Port 1	Port 2	Port 3
Switch State	'ON'	'ON'	'ON'
No.1	✓		
No.2		✓	
No.3	✓	✓	
No.4			✓
No.5	✓		✓
No.6		✓	✓
No.7	✓	✓	✓

The symbol '✓' means turning the switch to 'ON' position.

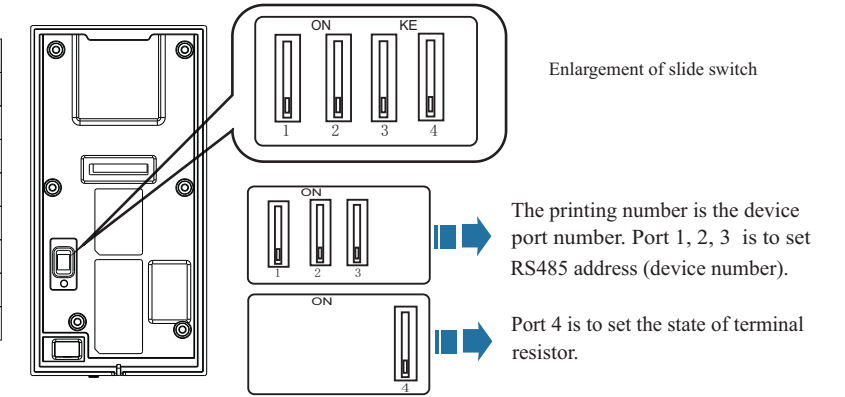
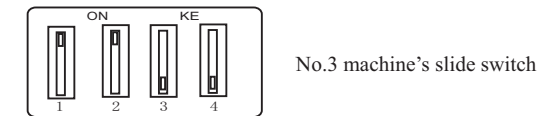

2. TCP/IP Mode:

(I) **Crossover cable:** The device and PC connected directly. As figure (9-2).

(II) **Straight cable:** The device and PC connected to LAN/WAN through switch/Lanswitch. As figure (9-3).

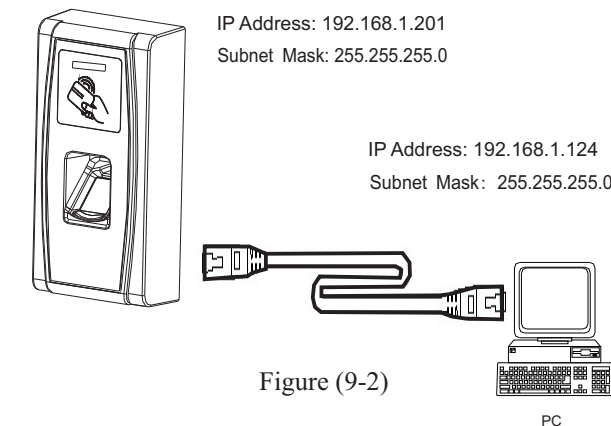

Figure (9-2)

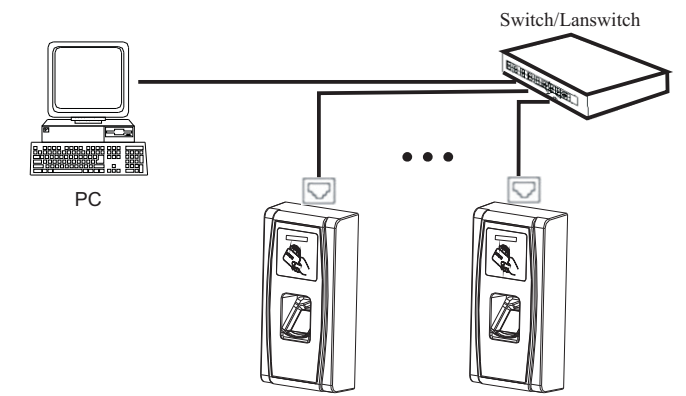

Figure (9-3)

3. 485Reader Function:

The MA300 supports the RS485 reader function, and it can be connected to the FR1200 reader through the RS485. The RS485 reader function can be switched by swiping the management card **seven times**.

1) After a user swipes the management card **seven times**, if the last time MA300 **beeps once**, that means RS485 reader function has been **disabled**. The MA300 communicates with the computer in RS485 mode.

2) After a user swipes the management card **seven times**, if the last time MA300 **beeps twice**, that means RS485 reader function has been **enabled**. The MA300 communicates with the RS485 reader.

Notes: When the communication distance between the FR1200 and master is longer than 100 m, the FR1200 must be powered separately.

To switch the communication function of the RS485 reader, you need to restart the device.

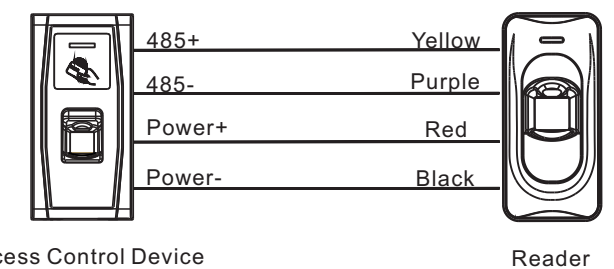

10. Cautions:

- (1) **Power cable is connected after all the other wiring.** If the device is working abnormally, please shut down the power first, then make the necessary check. Kindly reminds you that any hot-line work may damage the device, and it is not included in the warranty.
- (2) We recommend the 3A/12V DC Power supply. Please contact our technical staff for details.
- (3) **Please read carefully the terminal description and wiring by rule strictly.** Any damage caused by improper operations will not under warranty.
- (4) **Keep the exposed part of wire less than 5mm**, to avoid unexpected connection.
- (5) **Please connect the 'GND'** before all the other wiring especially under the environment with much electrostatic.
- (6) Do not change the cable type because of long distance between the power and the device. Pay attention to the distance voltage decay when you choose the power cable.

Warning: No operating with power on!